



KONICA MINOLTA

LIGHT & DISPLAY

Accurate and user-friendly solutions for the measurement of Light and Display

T-10A Series	Illuminance Meter
LS-150 / LS-160	Luminance Meter
CL-200A	Illuminance Colour Meter
CL-70F	CRI Illuminance Meter
CL-500A	Illuminance Spectrophotometer
CS-150 / CS-160	Colour Luminance Meter
CS-200	Luminance & Colour Meter
CS-2000 / CS-2000A	Spectroradiometer
CA-310	Display Colour Analyzer
CA-2500	2D Colour Analyzer

Giving Shape to Ideas

Compatible with new, next-generation light sources including PWM (Pulse Width Modulation) controlled sources.
 For simple but accurate illuminance measurements.
 Can be used to easily create a multi-point illuminance measurement system (up-to 30 points).

Illuminance Meter T-10A Series

→ Reliable, accurate illuminance meters that conform to JIS AA Class and DIN Class B

Illuminance Meters T-10A and T-10MA conform to Class AA of JIS C 1609-1: 2006 „Illuminance Meters Part 1: General measuring instruments“ and DIN 5032 Part 7 Class-B „Photometry; classification of illuminance meters and luminance meters“ requirements to reliably provide simple, high-accuracy measurements.

An Illuminance Meter that conforms to this standard is required for measurements of general illumination light sources, white LED lamps for illumination, etc. in a variety of industrial fields.



Standard receptor diffuser window: \varnothing 25 mm

T-10A
 Conforms to JIS AA Class and DIN class B
 Can be used for general measurements of illuminance.



T-10MA (Cord length: 1 m)
 Conforms to JIS AA Class and DIN class B
 Enables illuminance measurements of small areas. Can be used for illuminance measurements in narrow spaces where the standard receptor won't fit. It can also be easily installed on illuminance measurement jigs and other apparatus.

Mini receptor diffuser window: \varnothing 14 mm

Waterproof T-10WsA (Cord length: 5 m) T-10WLA (Cord length: 10 m)

Custom order Conforms to JIS requirements for special illuminance meters

The custom waterproof measuring heads are ideal for measurements in wet and humid conditions. They can be used for illuminance control for applications (such as fish farming) or for measuring outdoor illuminance on rainy days.

→ Removable receptor

The receptor and main body can be detached from each other and then connected using a LAN cable, making it easy to install as part of an inspection system.

→ Compatible with PWM-controlled lighting. Enables measurements of next-generation light sources.

Conventional illuminance meters often cannot accurately measure PWM-controlled light sources. The T-10A series of illuminance meters can be used to accurately measure PWM light sources.



→ Main applications

- Government testing organizations
- Research/inspection at illumination equipment manufacturers
- Maintenance at factories, offices, hospitals, etc.
- Illuminance control of security lighting, street lighting, etc.
- Sensor for equipment measuring light-distribution characteristics, etc.

→ Simple, inexpensive multi-point measurement (2 to 30 points)

Illuminance distribution of a projector etc. can be easily measured with a single instrument and several receptors.



→ Multi-point illuminance measuring system

- 5-point: Architectural lighting, etc.
- 9-point: Projectors, etc.
- 25-point: Street lighting, etc.

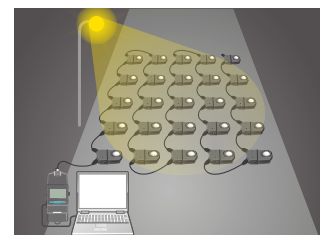
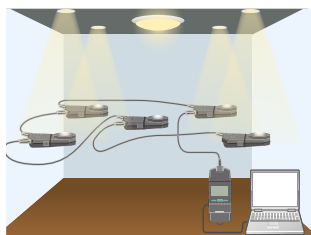

Model	Illuminance Meter T-10A (Standard receptor head)	Illuminance Meter T-10MA (Mini receptor head)	Illuminance Meter T-10WSA (Waterproof mini receptor head)	Illuminance Meter T-10WLA (Waterproof mini receptor head)
Illuminance meter class	Conforms to requirements for Class AA of JIS C 1609-1: 2006 „Illuminance meters Part 1: General measuring instruments“ Conforms to DIN 5032 Part 7 Class B		Conforms to requirements for special Illuminance meters of JIS C 1609-1: 2006	
Relative spectral response (f1)	Within 6% (f1) of the CIE spectral luminous efficiency V (λ)			
Cosine response (f2)	Within 3%		Within 10%	
Measuring range	Auto range (5 manual ranges at the time of analog output)			
Measuring range	Illuminance	0.01 to 299,900 lx; 0.001 to 29,990 fcd		1.00 to 299,900 lx; 0.1 to 29,990 fcd
	Integrated illuminance	0,01 to 999,900 × 10 ³ lx·h 0,001 to 99,990 × 10 ³ fcd·h / 0,001 to 9999 h		
User calibration function	CCF (Colour Correction Factor) setting function: Measurement value x 0.500 to 2.000			
Linearity	±2% ±1 digit of displayed value			
Temperature/ humidity drift	Within ±3%			
Display	3 or 4 Significant-digit LCD with backlight illumination (Automatic illumination)			

Luminance meters with improved accuracy and user-friendly features.

Luminance Meter LS-150 / LS-160

→ High accuracy

The LS-150 and LS-160 are lightweight, compact and battery powered luminance meters for the measurement of a wide range of luminance conditions. A worthy successor to the LS-100 and LS-110, the new instruments offer improved features and usability. These next generation instruments provide an increased measurement range and improved $V(\lambda)$ correlation (CIE relative photopic luminosity curve).

To provide the most accurate measurement of luminance, the relative spectral response of the measuring instrument should perfectly match the sensitivity of the human eye for photopic vision, as represented by the CIE spectral luminous efficiency $V(\lambda)$. Alongside improved usability, the LS-150/160 feature an improved correlation to $V(\lambda)$ and a greatly improved measurement range up to 999,900 cd/m^2 (LS-150) and 9,999,000 cd/m^2 (LS-160).

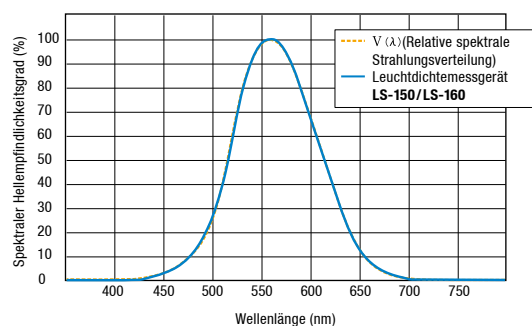

→ SLR (single-lens-reflex) optical system

The LS-150/160 single-lens-reflex design ensures that there is no difference between the area indicated in the viewfinder and the actual measurement area. The easy to use SLR optical system has been designed to be practically flare free which eliminates the effect of illumination outside the measurement area, ensuring accuracy.

→ Spot measurement for small target areas

The 1° acceptance angle of the LS-150 can measure areas with a diameter as small as 14.4 mm (at a distance of 1,014 mm); using the optional close-up lens, this can be reduced down to measurement diameters as small as 1.3 mm (at a distance of 205 mm).

The $1/3^\circ$ acceptance angle of the LS-160 can measure areas with a diameter as small as 0.4 mm (with close-up lens 110 attached).

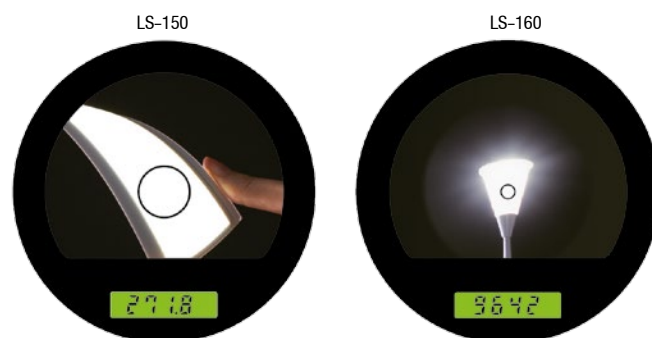

→ Large monochrome LCD Display with backlight

Measurement data is shown both inside the viewfinder and on the external display, supporting different modes of user operation.





Luminance Meter
LS-150 / LS-160

→ Lightweight and portable

Light weight, compact and battery powered, the LS-150/160 weighs just 850 g (not including batteries). These ergonomic and portable instruments include a hard case as standard, meaning they are easy to transport and operate for prolonged periods.

→ 10 Calibration channels available for calibration to a user reference light–source

The LS-150 & LS-160 can be calibrated to a user reference light source, this can be used to further reduce errors and improve inter instrument agreement when using multiple devices.



→ Measurement subjects

Practically anything that illuminates or reflects light can be measured with Konica Minolta's portable luminance meters.

- Measurement of the luminance of CRTs, LED's, and EL's.
- Measurement of road and tunnel brightness
- Measurement of rail-system signals
- Measurement of road and airport signals
- Measurement of illumination and outdoor signs
- Measurement of illumination equipment and devices
- Research and measurement testing
- Measurement of device brightness

Model	Colour Luminance Meter LS-150	Colour Luminance Meter LS-160
Measuring angle	1°	1/3°
Luminance meter class (Applicable standard)	DIN 5032-7 Class B compliant	(N/A)
Measurement mode	Instantaneous value, maximum/minimum value, luminance difference (Δ)/luminance ratio (%)	
Measurement time	AUTO: 0.7 to 4.3 seconds / Manual: 0.7 to 7.1 seconds	
Luminance range	0.001 to 999,900 cd/m ²	0.01 to 9,999,000 cd/m ²
Accuracy	$\pm 2\% \pm 2$ digits (1 cd/m ² or less) $\pm 2\% \pm 1$ digit (1 cd/m ² or more)	$\pm 2\% \pm 2$ digits (10 cd/m ² or less) $\pm 2\% \pm 1$ digit (10 cd/m ² or more)
Repeatability	0.2% + 1 digit	0.2% + 1 digit
User calibration channels	10 channels	
Data memory	1,000 data	

De facto industry standard for colour measurement of light sources.
Can measure colour temperature and dominant wavelength.

Illuminance Colour Meter CL-200A

→ Measure light-source colour and illuminance

The CL-200A Chroma Meter is a compact, lightweight, hand-held instrument for measuring the colour and illuminance of light sources (including new LED and EL light sources) and displaying the results in terms of tristimulus values, illuminance, chromaticity, dominant wavelength, excitation purity, correlated colour temperature, and difference values from a target.

→ Data transfer using main body buttons

When using the CL-200A with Data Management Software CL-S10w (included), measurements can be taken and data transferred to Excel® using the main body buttons as well as computer keys.

→ Detachable receptor head

The receptor head can be detached and then connected to the main body using a normal LAN cable*, making it easy to install the sensor in an inspection system.

* Optional Adapter Units required for receptor head and main body

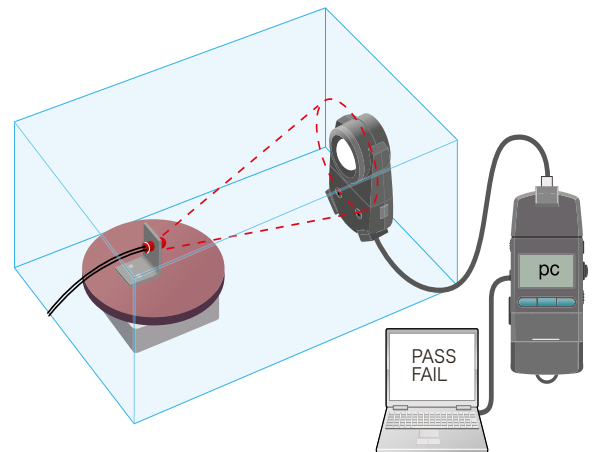

→ Multi-point illuminance measuring system

The receptor head can be detached from the main body and then connected at a distance using up to 30 measuring heads for multi-point measurements over a large area. In combination with the CL-S10w software one can simultaneously control all measurement points.

- 5-point: Architectural lighting, etc.
- 9-point: Projectors, etc.
- 25-point: Street lighting, etc.

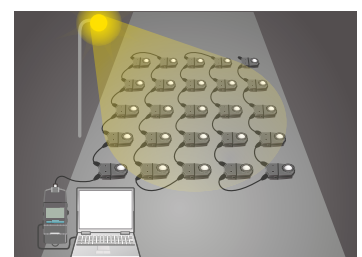
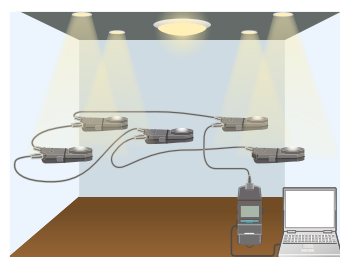



➔ **Ideal for quality control of white LED lamps**

White LEDs are typically made up of a blue LED which has been coated with a yellow phosphor material. The blue light emitted by the LED mixes with the yellow light emitted by the phosphor to create white light. Since the spectral emission distribution of the blue light emitted by the LED varies slightly for each unit, variations in the resulting white light will occur. For this reason it is important to control not only the brightness but also the colour of white LED's. The CL-200A can measure both the chromaticity and the light quality of the final white LED lamp assembled from multiple white LED's.

➔ **Excel® add-in software included**

Data Management Software CL-S10w (Standard accessory)

- **Easy, convenient Excel® add-in**
Measurement data from the CL-200A can be transferred directly into Excel®. The transferred data can then be managed freely within Excel®.
- **Includes LED ranking function**
Colour variations, can be quantified and a ranking function is also provided.
- **JIS correlated colour temperature**
Correlated colour temperature is determined using the equations defined by JIS (Japanese Industrial Standards).
- **Multi-point measurement and user calibration also possible**
Multi-point measurement management using up to 30 receptor heads is possible. User calibration function enables compensation of measurement values to match a desired standard. Calibration can be performed by two methods: Single-point calibration or RGB calibration.

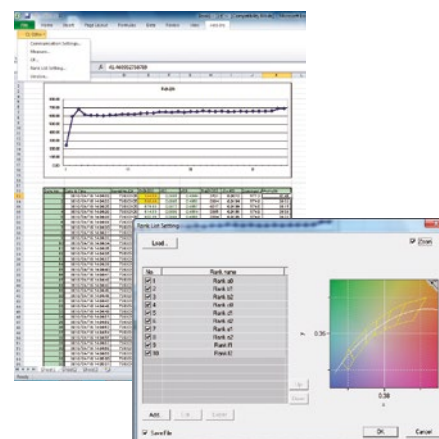

Model	Chroma Meter CL-200A
Luminance meter class	Conforms to requirements for Class AA of JIS C 1609-1: 2006 „Illuminance meters Part 1: General measuring instruments“
Relative spectral response (f1)	Closely matches CIE Standard Observer curves x(λ), y(λ), and z(λ). Within 6% (fi) of the CIE spectral luminous efficiency V(λ)
Cosine response (f2)	Ev: Within 3%
Measuring range	0.1 to 99,990 lx, 0.01 to 9,999 fcd (Chromaticity: 5 lx, 0.5 fcd or above) in four automatically selected ranges (lx or fcd is switchable)
User calibration function	CCF (Colour Correction Factor) setting function: Measurement value x 0.500 to 2.000
Temperature/ humidity drift	Ev: ±3% ±1 digit of displayed value, xy: ±0.003
Accuracy	Ev (Linearity): ±2%±1 digit of displayed value xy: ±0.002
Repeatability	Ev: 0.5%+1 digit (2σ), xy: ±0.0005

A cost effective portable illuminance meter with a user-friendly touch screen and a spectral sensor to measure CRI data.

CRI Illuminance Meter CL-70F

→ Cost effective solution for measuring light-source colour and illuminance

The CRI Illuminance meter CL-70F is a compact, lightweight, handheld instrument for measuring the colour and illuminance of light sources (including new LED and EL light sources). Measurement data is displayed in terms of CRI, tristimulus values, illuminance, chromaticity, dominant wavelength, excitation purity, correlated colour temperature, and difference values from a target.

The CL-70F can be used with a commercially available flash sync cable to take spectral measurements of photographic flash lights.

The utility software CL-SU1w is included as standard and adds further functionality for capturing and analysing data.

→ CRI measurement

The CL-70F provides easy access to CRI measurement data. The display shows the R_a value including all individual indices (R1 to R15) in a simple bar graph. For further information on colour rendering please see our light measurement resource.

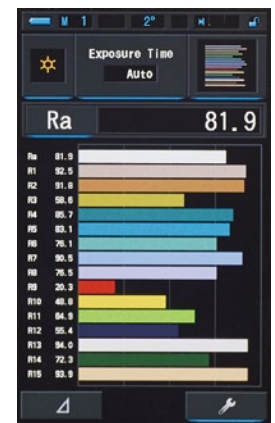

Colour rendering index

→ Easy measurement of correlated colour temperature (Tcp)

The CL-70F can measure correlated colour temperature and the difference from the blackbody locus Δuv , values which are often used to describe the colour of light sources. The colour temperature of light is defined as the absolute temperature (in Kelvin) at which a blackbody would emit that particular colour of light.

The colours of light emitted by a blackbody at various temperatures can be plotted on a curve which is called the „blackbody locus“. Since the output of many light sources do not lie directly on the blackbody locus, „correlated colour temperature“ is used to describe their colours. When describing a colour using correlated colour temperature, normally the difference from the blackbody locus Δuv is stated in addition to the correlated colour temperature.

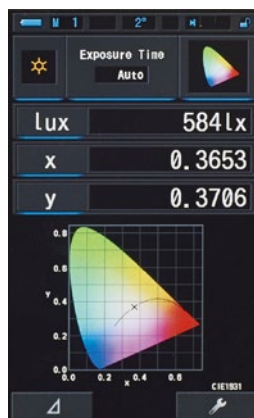

CIE1931 (CIE1964)

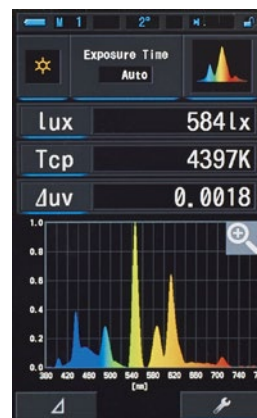

Spectrum



Text



→ Main features of CL-70F

The CL-70F is designed for a variety of common lighting tasks including lighting design and ongoing maintenance. Providing spectral information and CRI measurement the CL-70F provides entry level access to cutting edge light measurement features. Combining the instrument with a flash sync cable enables spectral measurements of flash light making the CL-70F a powerful tool for professional imaging and entertainment markets.

- Spectral sensor
- Measure CRI
- Compact, easy to carry & battery operated
- Colour touch screen

→ Easy zero-adjustment without a receptor cap

Slide the ring on the diffuser counterclockwise to perform dark calibration.



→ Rotating receptor head

The rotating receptor head improves screen visibility and comfortable use of the instrument.



Model	CRI Illuminance Meter CL-70F
Illuminance meter class	Conforms to requirements for Class A of JIS C1609-1:2006 „Illuminance meters Part1:General measuring instruments; Conforms to DIN 5032 Part 7 Class C
Spectral wavelength range	380 nm ~ 780 nm
Relative spectral response (f1)	Within 9%
Cosine response (f2)	Within 6%
Measuring range	Constant light: 1 to 200,000 lx; 1,563 to 100,000 K (Chromaticity display requires 5 lx or more) Flash light: 20 to 20,500 lx-s; 2,500 to 100,000 K
Accuracy (Standard Illuminant A)	$E_V: \pm 5\% \pm 1 \text{ digit of displayed value}$ $xy: \pm 0.003 \text{ (at 800 lx)}$
Colour indication modes	Correlated colour temperature T_{cp} , Difference from blackbody Δuv , XYZ, xy, u'v', Dominant wavelength λ_d , Excitation purity P_e , Spectral irradiance, E_v , CRI (Ra, Ri), Peak wavelength λ_p , exposure value
Temperature / humidity drift	$E_V: \pm 5\% xy: \pm 0.006 / E_V: \pm 3\% xy: \pm 0.006$

For evaluation of next-generation lamps such as LED illumination and EL illumination.
The CL-500A can also measure scotopic illuminance.

Illuminance Spectrophotometer CL-500A

→ Handheld illuminance spectrophotometer conforms to both DIN and JIS standards

The CL-500A conforms to DIN 5032 Part 7 Class B and JIS C 1609-1:2006 General Class AA, making it the first compact, lightweight, handheld illuminance spectrophotometer to conform to both DIN and JIS standards.

→ Compact, lightweight, handheld

The CL-500A weighs only 350g. It is extremely portable and easy to operate for prolonged periods.

→ High-speed measurement possible

Using the *SDK, high-speed measurements at 5 times/sec. can be taken.

*Software Development Kit

→ Built in display and controls. No PC required.

The CL-500A can be used for measuring CRI, illuminance and colour temperature of lamps without the need for extra hardware. The spectral irradiance waveform and peak wavelength can also be measured.

→ Measurement of spectral irradiance (w/m^2) at each wavelength.

The spectral irradiance can be measured at 1-nm pitch from 360 to 780 nm, so the CL-500A can be used not only for measuring the colour of light but also for measuring photosynthetic photon flux density (PPFD).

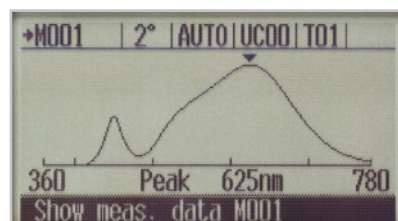

→ Excel® add-in software included

Data Management Software CL-S10w (Standard accessory)

- **Easy-to-use Excel® add-in software**

Reads measurement data from the CL-500A directly into Excel®. Further processing and storage of data can then be performed easily within Excel®.

- **Spectral irradiance waveform display**

Since peak wavelengths can be seen easily, classification and grading of light sources can be performed quickly and accurately. In addition, numerical data at 1 nm can also be viewed in list form.

- **Multi-point measurement possible using multiple CL-500A units**

Data Management Software CL-S10w can be used to control up to 10 CL-500A units for multi-point measurements. Using the SDK, this can be further expanded.





➔ Measures and displays both the general colour-rendering index R_a as well as the special colour-rendering indexes R1 to R15

Using the CL-S10w software colour-rendering indexes are shown visually for easy evaluation. The shifts between a test light source and a standard light source can be seen at a glance, with bar graphs showing the general colour-rendering index R_a (the average of special colour-rendering indexes R1 to R8) and the special colour-rendering indexes for a total of 15 colours (R1 to R15).

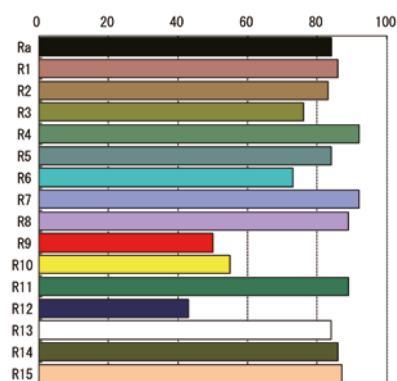

➔ Scotopic illuminance can also be measured

Most conventional illuminance meters can only measure photopic illuminance, but the CL-500A can measure both photopic and Scotopic (dark-adapted) illuminance (using either the built in display or the CL-S10w Software). The S/P ratio of Scotopic illuminance and photopic illuminance can also be displayed.

Model	CRI Illuminance Meter CL-500A
Illuminance meter class	Illuminance meter class Conforms to requirements for Class AA of JIS C 1609-1: 2006 „Illuminance meters Part 1: General measuring instruments“ Conforms to DIN 5032 Part 7 Class B
Wavelength range	380 nm ~ 780 nm
Accuracy (Standard illuminants A)	E_v (Illuminance) : $\pm 2\% \pm 1$ digit of displayed value xy : ± 0.0015 (10 to 100,000 lx) ; xy : ± 0.002 (5 to 10 lx)
Relative spectral response (f1)	Within 1.5% of spectral luminous efficiency $V(\lambda)$
Cosine response (f2)	E_v : Within 3%
Measuring range	ϕ 0.1 to 100,000 lx (chromaticity display requires 5 lx or more)
Temperature/ humidity drift	E_v : $\pm 3\%$ of displayed value; xy : ± 0.003
Display modes	XYZ; $X_{10}Y_{10}Z_{10}$; E_vxy ; $E_vu'v'$; E_v ; Dominant wavelength, Excitation purity; Correlated colour temperature, Δuv ; General colour-rendering index (R_a); Special colour-rendering indexes (R_i ($i=1\sim 15$)); Spectral graph; Peak wavelength; Δ (XYZ); Δ ($X_{10}Y_{10}Z_{10}$); Δ (E_vxy); Δ ($E_vu'v'$); Rank display

A compact, lightweight, instrument with a 1° measurement angle for high-accuracy non-contact measurements of luminance and chromaticity.

Colour Luminance Meter CS-150 / CS-160

→ Spot measurement of colour and luminance in a handheld portable instrument

The CS-150 and CS-160 are lightweight, compact and battery powered luminance and colour meters for the measurement of a wide range of luminance conditions and non contact measurement of colour. A worthy successor to the CS-100A, the new instruments offer improved features and usability. These next generation instruments provide an increased measurement range and a sensor that more closely matches the CIE 1931 colour-matching functions.

To provide the most accurate measurement of luminance, the relative spectral response of the measuring instrument should perfectly match the sensitivity of the human eye for photopic vision, as represented by the CIE spectral luminous efficiency $V(\lambda)$. Alongside improved usability, the CS-150 and CS-160 feature an improved correlation to $V(\lambda)$ and a greatly improved measurement range up to 999,900 cd/m² (CS-150) and 9,999,000 cd/m² (CS-160).

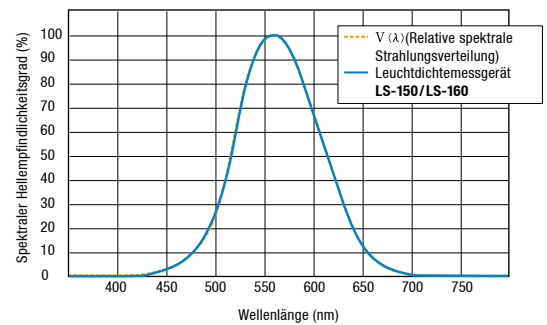

→ SLR (single-lens-reflex) optical system

The CS-150/160 single-lens-reflex design ensures that there is no difference between area indicated in the viewfinder and the actual measurement area. The easy to use SLR optical system has been designed to be practically flare free which eliminates the effect of illumination outside the measurement area, ensuring accuracy.

→ Spot measurement for small target areas

The 1° acceptance angle of the CS-150 can measure areas with a diameter as small as 14.4 mm (at a distance of 1,014 mm); using the optional close-up lens, this can be reduced down to measurement diameters as small as 1.3mm (at a distance of 205 mm).

The 1/3° acceptance angle of the CS-160 can measure areas with a diameter as small as 0.4 mm (with close-up lens 110 attached).

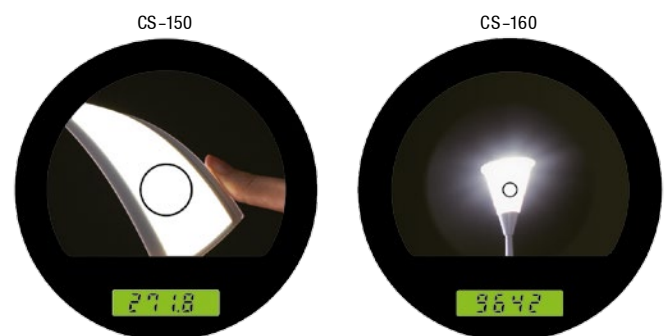

→ Provides tristimulus colour data

The colour of the object inside the measuring area can be measured quickly without the influence of the surrounding area and without needing to touch the sample.





Colour Luminance Meter
CS-150 / CS-160

→ **10 Calibration channels available for calibration to a user reference lightsource**

The CS-150 can be calibrated to a user reference light source, this can be used to further reduce errors and improve inter instrument agreement when using multiple devices.

→ **USB 2.0 communication**

Connect with a PC via USB 2.0 to send measurement data and receive control signals. The instrument can also be powered by USB cable, ideal for use in measuring rigs or when working with a PC/tablet computer. Data-management software CS-S20 is included as a standard accessory.



→ **Measurement subjects**

Practically anything that illuminates or reflects light can be measured with Konica Minolta's portable luminance meters.

- Measurement of the luminance of CRTs, LED's, and EL's
- Measurement of road and tunnel brightness
- Measurement of rail-system signals
- Measurement of road and airport signals
- Measurement of illumination and outdoor signs
- Measurement of illumination equipment and devices
- Research and measurement testing
- Measurement of device brightness

Model	Luminance & Colour Meter CS-150	Luminance & Colour Meter CS-160
Measuring angle	1°	1/3°
Angle of view	9° (with diopter adjustment)	
Measurement mode	Luminance: Instantaneous value, maximum/minimum value, luminance difference (Δ)/luminance ratio (%) / Chromaticity: Instantaneous value, chromaticity difference (Δ)	
Measurement time	AUTO: 0.7 to 4.3 seconds / Manual: 0.7 to 7.1 seconds	
Luminance range	0.01 to 999,900 cd/m ²	0.1 to 9,999,000 cd/m ²
Accuracy	Luminance: $\pm 2\% \pm 1$ digit / Chromaticity: ± 0.004 (50 cd/m ² or more)	Luminance: $\pm 2\% \pm 1$ digit / Chromaticity: ± 0.004 (50 cd/m ² or more)
Repeatability	Luminance: 0.2% + 1 digit Chromaticity: 0.001 (10 cd/m ² or more) Chromaticity : 0.002 (5 cd/m ² or more)	Luminance: 0.2% + 1 digit Chromaticity: 0.001 (100 cd/m ² or more) Chromaticity : 0.002 (50 cd/m ² or more)
User calibration channels	10 channels	
Data memory	1,000 data	

The CS-200 Chroma Meter measures luminance and chromaticity of light emitting products as diverse as large plasma displays, compact LCDs and LEDs, outdoor screens, high pressure lamps, and instrument panels.

Luminance & Colour Meter CS-200

→ Perfect match of the spectral response to the CIE colour-matching functions

Konica Minolta's spectral fitting method provides tristimulus values (XYZ = red, green, blue) with significantly higher accuracy than that of conventional tristimulus colorimeters. This is achieved by using the output from 40 sensors to calculate the spectral response corresponding to human eye sensitivity (CIE 1931 colour-matching functions).

The CS-200 uses 40 sensors for sensitivity covering the entire visible region and multiplies each sensor output by appropriate coefficients. This adjusts the spectral response of the instrument to close to the CIE 1931 colour-matching functions. In addition to the 2° Standard Observer, the 10° Standard Observer (for object-colour measurements) can also be selected.

→ Compact and lightweight

The compact, lightweight body allows hand-held operation. The CS-200 can be operated with either four AA batteries (battery indicator function provided) or AC adapter.

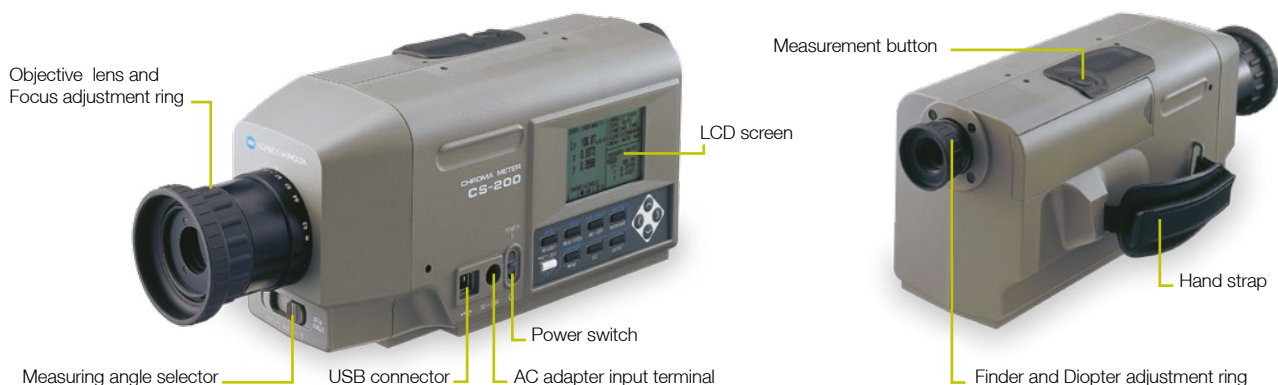

→ Data Management Software CS-S10w Standard (Standard accessory)

CS-S10w Standard Edition allows users to control the CS-200 with a PC to display the list of measured data or to transfer the data to a spreadsheet.

Functions common to Standard and Professional Editions	
Colour space	L_v x y, L_v u' v', L_v TΔuv, XYZ, dominant wavelength
Mode selection	Normal mode / Object colour mode
Instrument control	Average measurement Interval measurement User calibration
Data management	Reading and saving files Data management with folders
Data evaluation:	Observer / Illuminant settings Statistics display for each folder Box tolerance setting

Data Management Software CS-S10w Professional (Optional accessory)

In addition to the functions of Standard Edition, optional CS-S10w Professional Edition enables various data management, analysis and evaluation functions developed for R&D or quality control applications.

Functions available only with Professional Edition	
Mode selection	Contrast mode RGB mode RGB & contrast mode
Data management	Creating, saving and loading templates (customizable design/layouts for various graphs) Various graph displays
Data evaluation	Multiple-point measurement, uniformity display, contrast display and polygon tolerance setting for display evaluation
Data management	Creating reports in customizable screen layouts



→ Selectable measuring angle

The user can select the appropriate measuring angle easily according to the application (1°, 0.2° and 0.1°). The aperture mirror eliminates misalignment between the finder target and the actual measurement area, ensuring accurate aiming.



1° aperture

For measurement of general-size areas such as medium and large displays.

- LCD, PDP, or EL display panels
- LCD panels of mobile phones or digital cameras
- Light sources such as lamps or fluorescent tube backlights
- Radar or other instrument panels in aircraft cockpits
- Large outdoor display screens

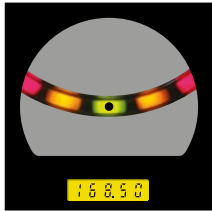

0.2° aperture

For measurement of small areas such as product LEDs.

- Sub-display of mobile phones
- Car audio equipment
- Automobile instrument panels

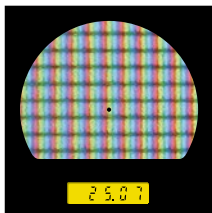

0.1° aperture

For measurement of very small areas or of a distant light source.

- Pixels of a PDP or LCD
- Cold cathode tube
- Automobile lamps
- Signal lights

Model	Luminance & Colour Meter CS-200			
Measuring range	0.01 - 200,000cd/m ² (Measuring angle 1°) 0.01 - 5,000,000cd/m ² (Measuring angle 0.2°) 0.01 - 20,000,000cd/m ² (Measuring angle 0.1°)			
Accuracy (Measuring angle 1°) (Standard Illuminant A; Temperature: 23°C ±2°C, Relative humidity: 65% max.)	150 cd/m ² 0.01-0.5 cd/m ² 0.5-1 cd/m ² 1-10 cd/m ² 10-200,000 cd/m ²	L _v ± 2% ±1digit L _v ± 0.02 cd/m ² ±1digit L _v ± 0.02 cd/m ² ±1digit L _v ± 2% ±1digit L _v ± 2% ±1digit	xy ± 0.002 --- xy ± 0.007 xy ± 0.004 xy ± 0.003	
	Light source at 5000 cd/m ² + colour filter (R, G, B)		xy ± 0.006	
Repeatability (Measuring angle 1°) (Standard Illuminant A)	0.01-1 cd/m ² 1-2 cd/m ² 2-4 cd/m ² 4-8 cd/m ² 8-200,000 cd/m ²	L _v 0.01 cd/m ² +1digit L _v 0.5% +1digit L _v 0.5% +1digit L _v 0.5% +1digit L _v 0.1% +1digit	--- xy 0.002 xy 0.001 xy 0.0005 xy 0.0004	(2σ/AUTO) (2σ/AUTO) (2σ/AUTO) (2σ/AUTO) (2σ/AUTO)
Measurement method	Spectral method, Grating + linear photo diode array			
Measuring angle	1°, 0.2°, 0.1° (switchable)			
Measurement synchronization setting	Vertical synchronization frequency: 40.00 to 200.00Hz			
Temperature/ humidity drift	0°C to 40°C, relative humidity 85% or less (at 35°C) with no condensation			
Power source	AC adapter or 4 AA-Size Batteries			

Spectroradiometers that push the boundaries of low light and display contrast measurement.

Spectroradiometer CS-2000 / CS-2000A

CS-2000A

1,000,000:1 contrast measurement! *When the peak luminance is 500 cd/m²

The Spectroradiometer CS-2000A enables high-accuracy mega-contrast measurements of the extremes from delicate shadows to glittering wavefronts which are key to image reproduction performance. Konica Minolta Spectroradiometers are widely used in both research and development as well as quality control of the most advanced FPDs.

→ 0.0005 cd/m² opens new worlds

Extending the low level luminance measurement performance even compared to our CS-2000. The CS-2000A has opened up a new stage of display development by enabling the measurement of contrast ratios up to 1 million to 1¹.

*1 Maximum luminance 500 cd/m²

CS-2000

Pushing the boundaries of practical application and cost performance to support design and development work.

→ Highly accurate measurement of luminances as low as 0.003 cd/m²

Konica Minolta's proprietary optical design and signal-processing technologies provide accurate measurement of luminance/chromaticity down to low luminances of 0.003 cd/m².

- Low-luminance measurements: From 0.003 cd/m²
- Measurement accuracy: ±2% (Luminance)

→ Low polarization error

The polarization error generated when using a reflection-type diffraction grating has been minimized to 2% (measuring angle: 1°). This ensures more stable measurements of display devices that use polarization, such as LCDs.

→ Practical design

- The operating temperature range of 5 to 35°C ensures reliable operation at temperatures in actual work environments.
- Measurement can be started after a warm-up time of only 30 seconds. (Measuring angle: 1°; Target luminance: 5 cd/m² or more; 23°C)





→ Selectable measuring angle for measurement of tiny areas

The CS-2000 enables you to select the optimum measuring angle according to the application.

- Measuring angle selection: 1°, 0.2°, 0.1°
- Minimum measuring area: \varnothing 0.1 mm (when the optional close-up lens is attached)

→ Easy operation with colour screen and control panel

The colour LCD screen and control panel are located at the rear of the instrument, enabling easy operation of the key device functions.

Colour space mode screen

```

<MEAS SNGL> UC00 T01
Lv 30.79  $\frac{cd}{m^2}$ 
x 0.3211
y 0.3404
0BS SPD SYNCLEN ND BL
10° Fst Int StdNonoff

<MEAS SNGL> UC00 T01
Lv 30.79  $\frac{cd}{m^2}$ 
T 6027K
duv +0.005
0BS SPD SYNCLEN ND BL
10° Fst Int StdNonoff

<MEAS SNGL> UC00 T01
380 ← 380nm → 780
6.0018E-8
0BS SPD SYNCLEN ND BL
10° Fst Int StdNonoff

```

Menu screen

```

MENU
MEAS
SPEED MODE
MANUAL
INTEG TIME
1000.000 ms
IN-ND OFF

MENU
MEAS
SYNC MODE
INT SYNC
000.00 Hz

MENU
SETUP
OBSERVER
2° OBS
10° OBS

```

Simple operation
The desired function can be easily operated.

Easy connection via USB

Model	Spectroradiometer CS-2000	Spectroradiometer CS-2000A
Measurement angle	0.1°, 0.2°, 1° selectable	
Measurement wavelength range	380 ~ 780 nm	
Wavelength resolution	0.9 nm/pixel	
Display wavelength pitch	1.0 nm	
Half bandwidth (FWHM)	5 nm or less	
Luminance measurement range (for Standard illuminant A)	0.1° measurement angle: 0.3 to 500,000 cd/m ² 0.2° measurement angle: 0.075 to 125,000 cd/m ² 1° measurement angle: 0.003 to 5,000 cd/m ²	0.1° measurement angle: 0.05 to 500,000 cd/m ² 0.2° measurement angle: 0.0125 to 125,000 cd/m ² 1° measurement angle: 0.0005 to 5,000 cd/m ²
Accuracy	Luminance	±2%
	Chromaticity (1°)	x,y : ±0.0015 (>0.05 cd/m ²)
Repeatability	Luminance (1°)	0.15% (0.1 to 5000 cd/m ²)

Enables high-accuracy adjustment of EL/LED-backlit LCD TV gamma/white balance to greatly improve efficiency in manufacturing, QC and calibration.

Display Colour Analyzer CA-310

→ Improved performance when measuring LED-backlit LCD TVs

The Display Colour Analyzer CA-310 is a high accuracy instrument for measuring LED-backlit LCD TVs and other backlit displays. Although conventional backlights such as fluorescent lamps provide relatively uniform light, the spectral emission distribution of LEDs varies slightly with each unit. The CA-310 overcomes this problem with colour sensors that more closely match the CIE 1931 colour-matching functions, offering higher measurement accuracy while providing high measurement speed even at low luminances.

→ Enables high-speed measurement, even at extremely low luminances (down to 0.005 cd/m²)

Sensor noise reduction technology has been used to enable measurements even in the extremely low luminance region around 0.005 cd/m² at speeds as fast as 4 times per second. This allows the high-speed high-accuracy measurement essential for manufacturing high-grade displays. In addition, at luminances higher than 2.0 cd/m², 20 measurements per second are possible.

→ Reduces errors due to LED emission distribution variations to less than 1/3

Variations in the emission distribution of LED backlights result in individual differences of about 10nm in peak intensity wavelength. If LED-backlit LCD TVs with such individual differences are adjusted using conventional colour analyzers, colour differences of close to 0.010 on the xy chromaticity diagram may occur. Using the CA-310, the colour difference in the same case would be reduced to around 0.003.





➔ Probe variations

This table is based on the most popular method for controlling emission intensity for each display type.

Measurements of displays using certain control methods are not possible. For details of measurement compatibility, contact your nearest Konica Minolta representative.

Examples for which measurement is not possible:

- Displays which use PWM, etc. for control of emission intensity.
- Displays with backlights which emit intermittently.
- Displays which write black for each frame, etc.

○ Recommended

△ Measurement possible with restrictions, but probes marked with ○ are recommended

× Measurement not possible

			CA-310 Probe			
			LED Universal Measuring Probe		LED Flicker Measuring Probe	
			Ø27 Probe CA-PU32 (2m) CA-PU35 (5m)	Ø10 Probe CA-PSU32 (2m) CA-PSU35 (5m)	Ø27 Probe CA-P32 (2m) CA-P35 (5m)	Ø10 Probe CA-PS32 (2m) CA-PS35 (5m)
Applicability for different display types						
Transmissive / semi-transmissive LCD	Active Matrix Driven		○	○	○	○
	Passive Matrix Driven		○	○	×	×
OLED	Active Matrix Driven		○	○	○	○
	Passive Matrix Driven		○	○	×	×
PDP			○	△	×	×
FED			○	○	×	×
Rear Screen Projector	LCD	Active Matrix Driven	○	△	○	△
		Passive Matrix Driven	○	△	×	×
	DLP		○	△	×	×
CRT			○	△	×	×

Model	CA-310 (LED Universal Measuring Ø27 Probe)	CA-310 (LED Universal Measuring Ø10 Probe)	CA-310 (LED Flicker Measuring Ø27 Probe)	CA-310 (LED Flicker Measuring Ø10 Probe)
Measurement area	ø27mm	ø10 mm	ø27 mm	ø10 mm
Acceptance angle	±2.5°	±5°	±2.5°	±5°
Display range	Luminance			
	Measurement range	0.0001 - 1000 cd/m ²	0.0001 - 3000 cd/m ²	0.0001 - 1000 cd/m ²
	Accuracy (for white)	0.0050 - 1000 cd/m ²	0.0150 - 3000 cd/m ²	0.0050 - 1000 cd/m ²
	Repeatability (2σ)	10.00 - 1000 cd/m ² ±2%±0.0010 cd/m ²	30.00 - 3000 cd/m ² ±2%±0.0030 cd/m ²	30.00 - 3000 cd/m ² ±2%±0.0030 cd/m ²
	Repeatability (2σ)	1.000 - 1000 cd/m ² 0.1%+0.0010 cd/m ²	3.000 - 3000 cd/m ² 0.1% + 0.0030 cd/m ²	1.000 - 1000 cd/m ² 0.1%+0.0010 cd/m ²
	Repeatability (2σ)	3.000 - 3000 cd/m ² 0.1% + 0.0030 cd/m ²	1.000 - 1000 cd/m ² 0.1%+0.0010 cd/m ²	3.000 - 3000 cd/m ² 0.1% + 0.0030 cd/m ²
Chromaticity	Measurement range	0.0500 - 1000 cd/m ²	0.1500 - 3000 cd/m ²	0.0500 - 1000 cd/m ²
	Accuracy	0.1500 - 3000 cd/m ²	0.0500 - 1000 cd/m ²	0.1500 - 3000 cd/m ²
	Accuracy	120 cd/m ² ±0.002 for white (±0.004 for monochrome)		
	Repeatability(2σ)	0.5000 to 1000 cd/m ² 0.001	1.500 to 3000 cd/m ² 0.001	0.5000 to 1000 cd/m ² 0.001
Display	Digital	xyLV, TΔuvLV, RGB analyze, XYZ, u'v'LV		xyLV, TΔuvLV, RGB analyze, XYZ, u'v'LV, Flicker (Contrast method)
	Analog	ΔxΔyΔLV, R/G B/G ΔG, ΔR B/R G/R		ΔxΔyΔLV, R/G B/G ΔG, ΔR B/R G/R, Flicker (Contrast method)
	LCD	16 characters by 2 lines (with backlight)		

The CA-2500 can be used for display colour measurement in a variety of applications, such as display, illumination, automotive, aviation, and other industries.

2D Colour Analyzer CA-2500

→ High-accuracy measurements of two-dimensional colour distribution

An instrument for high-resolution, two-dimensional measurement of the luminance distribution and chromaticity distribution of FPDs, projectors, backlights, etc. The CA-2500 is a powerful tool for development evaluation or product inspection, providing efficient measurement, analysis and evaluation.

→ XYZ filters provide high correlation with the spectral response of the human eye

Instead of the RGB colour-separation filters used by digital video cameras, etc., the CA-2500 uses XYZ filters that closely match the CIE 1931 colour-matching functions to provide luminance and chromaticity measurements that have high correlation with the spectral response of the human eye.

→ Interchangeable lenses for measurements of various subjects

Standard, wide-angle, and telephoto lenses (plus two macro rings for the telephoto lens) are available, enabling the optimum lens to be selected according to the particular subject, measurement area, or measurement method.

→ Comprehensive factory calibration

Each lens is individually factory-calibrated at multiple focal points to correct for sensitivity variations due to the combination of sensor, optical filters, and the lens itself. By using the included calibration data, high-accuracy measurements of luminance and chromaticity distribution can be taken immediately after receiving the product without being restricted to a particular measurement method, subject size or subject brightness.

→ Includes advanced Data Management Software CA-S25w as standard accessory

Advanced functions such as focus assist, positioning assist, and automatic measurement area extraction greatly simplify operation and data evaluation.

→ Includes SDK (software development kit)

The SDK can be used by to create bespoke software solutions for controlling the CA-2500. SDK for Labview® also available.

→ Optional Mura Evaluation Software

This optional software uses an exclusive algorithm to enable mura (unevenness) evaluation that more closely correlates with visual evaluation.

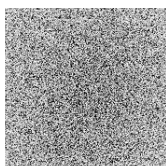

L* edge

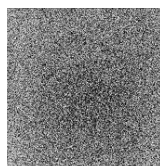

C* edge



Uneven L* Area

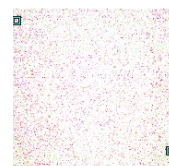

Uneven C* Area



➔ Even flickering light sources such as OLED televisions or PDP can be measured accurately

The synchronization frequency (4 to 2,000 Hz) of display devices and pulsed light sources can be input to enable synchronized measurements.

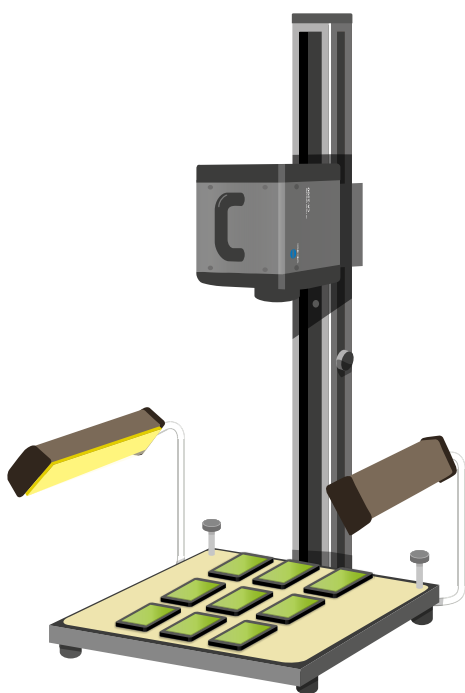

➔ Low-luminance measurement

The minimum measurable luminance of the CA-2500 is 0.05 cd/m².

➔ Applications

- Simultaneous luminance/chromaticity distribution measurement of multiple small- or medium-sized LCD or organic EL panels
- Luminance/chromaticity measurement of single large-sized LCD or organic EL panels
- Display mura (unevenness) evaluation
- Luminance distribution measurements in illumination field
- Measurements of luminance/correlated colour temperature distribution of various light-emitting subjects
- Luminance distribution measurements of automobile instrument panel meters
- Measurement of distribution of luminance and chromaticity on screen image from projectors

Model	CA-2500S	CA-2500W	CA-2500T
Light Receptor	CCD Image sensor (Monochrome) 2/3 inch. Effective number of pixels 1,000 x 1,000.		
Lens	Interchangeable; Standard, Wide, Tele		
Measurement points (Resolution)	980 x 980 (490 x 490 or 196 x 196) selectable by using Data Management Software		
Luminance range	0.05 - 100,000 cd/m ²	0.05 - 100,000 cd/m ²	0.25 - 100,000 cd/m ²
Measurement time	Single: Approx 5 sec. or more;		
Accuracy	Luminance	±3%	±3%
	Chromaticity	±0.005	±0.005
Repeatability	Luminance	0.005	0.005
	Chromaticity	0.001	0.001
Measurement sizes	Approx 98 mm or more (Depending on the distance)	Approx 145 mm or more (Depending on the distance)	Approx 115 mm or more (Depending on the distance)

T-10A Series - Main Specifications and Accessories

Model	Illuminance Meter T-10A (Standard receptor head)	Illuminance Meter T-10MA (Mini receptor head)	Illuminance Meter T-10WsA (Waterproof mini receptor head)	Illuminance Meter T-10W.A (Waterproof mini receptor head)
Type	Multi-function digital illuminance meter with detachable receptor head (Multi-point measurements of 2 to 30 points is possible)			
Illuminance meter class	Conforms to requirements for Class AA of JIS C 1609-1: 2006 "Illuminance meters Part 1: General measuring instruments" Conforms to DIN 5032 Part 7 Class B		Conforms to requirements for special Illuminance meters of JIS C 1609-1: 2006 *1	
Receptor	Silicon photoceII			
Relative spectral response	Within 6% (f_1) of the CIE spectral luminous efficiency $V(\lambda)$			
Cosine response (f_2)	Within 3%		Within 10%	
Measuring range	Auto range (5 manual ranges at the time of analog output)			
Measuring function	Illuminance (lx), illuminance difference (lx), illuminance ratio (%), integrated illuminance (lx-h), integration time (h), average illuminance (lx).			
Measuring range	Illuminance	0.01 to 299,900 lx; 0.001 to 29,990 fcd		1.00 to 299,900 lx; 0.1 to 29,990 fcd *2
	Integrated illuminance	0.01 to 999,900 x 10 ³ lx-h 0.001 to 99,990 x 10 ³ fcd-h / 0.001 to 9999 h		
User calibration function	CCF (Colour Correction Factor) setting function: Measurement value x 0.500 to 2.000			
Linearity	±2% ±1 digit of displayed value			
Temperature/ humidity drift	Within ±3%			
Digital output	USB			
Analog output	1 mV/digit, 3 V at maximum reading; Output impedance: 10 KΩ; 90% response time: 28 ms			
Display	3 or 4 Significant-digit LCD with backlight illumination (Automatic illumination)			
Power source	2 AA-size batteries / AC adapter AC-A308 (optional; for 1 to 10 receptors) or AC adapter AC-A311 (optional; for 1 to 30 receptors)			
Battery life	72 hours or longer (when alkaline batteries are used) in continuous measurement			
Operating temperature / humidity range	-10 to 40°C, relative humidity 85% or less (at 35°C) with no condensation		5 to 40°C, relative humidity of 85% or less (at 35°C) with no condensation	
Storage temperature / humidity range	-20 to 55°C, relative humidity 85% or less (at 35°C) with no condensation		0 to 55°C, relative humidity of 85% or less (at 35°C) with no condensation	
Size	69 × 174 × 35 mm	Main body: 69 × 161.5 × 30 mm / Receptor: ø16.5 × 13.8 mm		
Cord length	-	1 m	5 m	10 m
Weight (without battery)	200 g (7.0 oz.)	205 g	260 g (Receptor head only: 120 g)	340 g (Receptor head only: 200 g)

*1 Conforms to requirements for Class AA of JIS C 1609-1: 2006 for all items except cosine response (f2).

*2 Although measurements below 1.00 lx are possible, they may not be stable due to the effects of electrical noise.

<Notes regarding mini receptors and waterproof mini receptors>

*Do not touch the cable during measurements. Doing so may result in unstable measurement values.

*Secure the cable during measurements. Failure to do so may result in unstable measurement values.

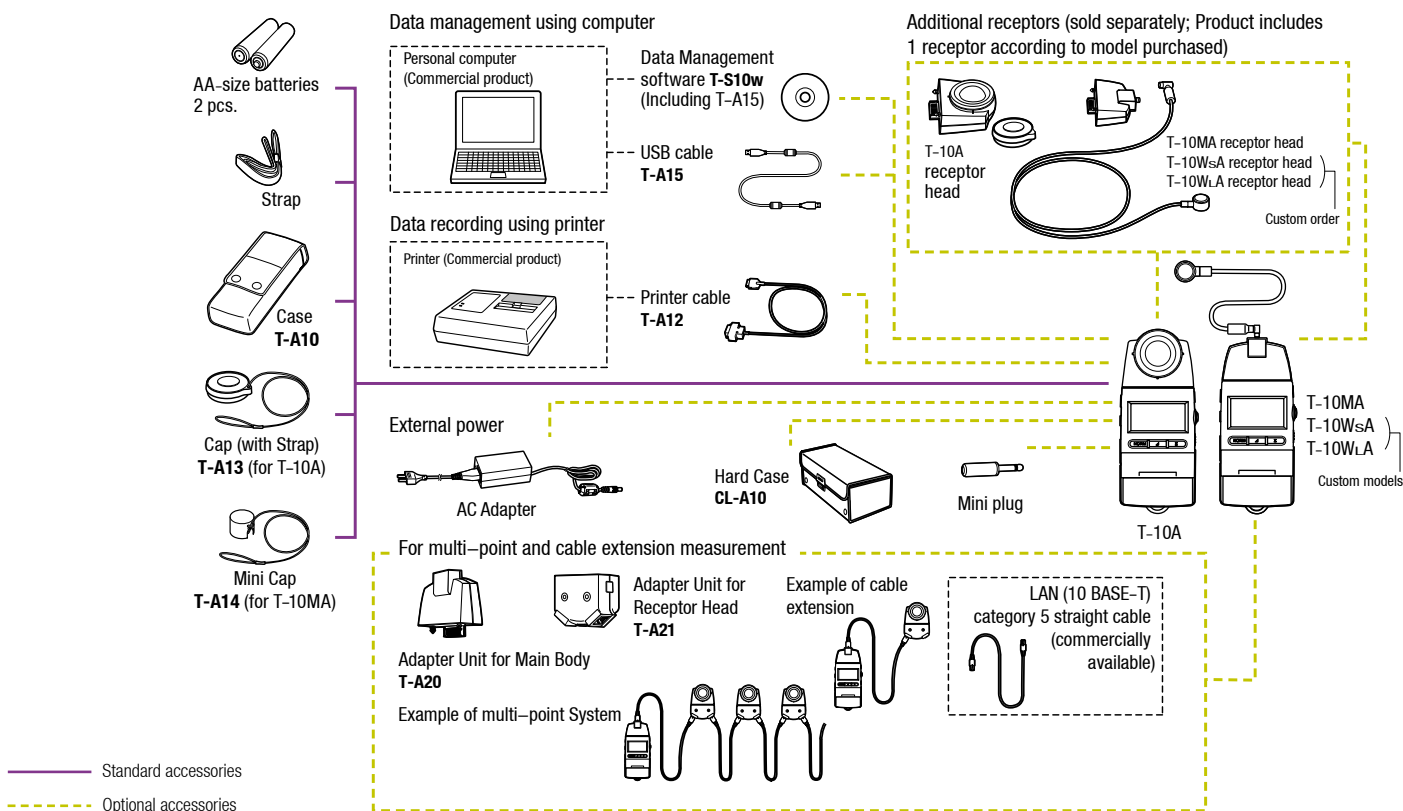

LS-150 / LS-160 - Main Specifications and Accessories

Model	Colour Luminance Meter LS-150	Colour Luminance Meter LS-160
Measuring angle	1°	1 / 3°
Optical system	SLR viewing system, f t 85 mm F2.8	
Angle of view	9° (with diopter adjustment)	
Relative spectral responsivity	Closely matches spectral luminous efficiency (V (λ))	
Applicable standard	DIN 5032-7 Class B compliant	(N/A)
Minimum measuring area (diameter)	14.4 mm (1.3 mm when close-up lens is used)	4.5 mm (0.4 mm when close-up lens is used)
Minimum measuring distance (From the measuring distance reference plane)	1,012 mm (213 mm when close-up lens is used)	
Measurement mode	Instantaneous value, maximum/minimum value, luminance difference (Δ)/luminance ratio (%)	
Measurement time	AUTO: 0.7 to 4.3 seconds / Manual: 0.7 to 7.1 seconds	
Luminance unit	cd /m ² or fL	
Luminance range	0.001 to 999,900 cd /m ²	0.01 to 9,999,000 cd /m ²
Accuracy ^{*1}	±2% ± 2 digits (1 cd /m ² or less) ±2% ± 1 digit (1 cd /m ² or more)	±2% ± 2 digits (10 cd /m ² or less) ±2% ± 1 digit (10 cd /m ² or more)
Repeatability ^{*1}	0.2% + 1 digit	0.2% + 1 digit
Calibration standard	Konica Minolta standard /user-specified standard switchable	
User calibration channels	10 channels	
Data memory	1,000 data	
External display (Number of significant digits)	4 digits	
Internal display (Number of significant digits)	4 digits	
Interface	USB 2.0	
Power	AA-size bat teries (x2), USB bus power or optional AC	
Current consumption	When viewfinder display is lit: 70 mA average	
Operation temperature / humidity range	0 to 40°C, relative humidity of 85% or less (at 35°C)	
Storage temperature / humidity range	0 to 45°C, relative humidity of 85% or less (at 35°C)	
Size	71 × 214 × 154 mm	
Weight (without battery)	850 g	

^{*1} Standard Illuminant A; Standard measurement distance; Measurement time setting: Auto

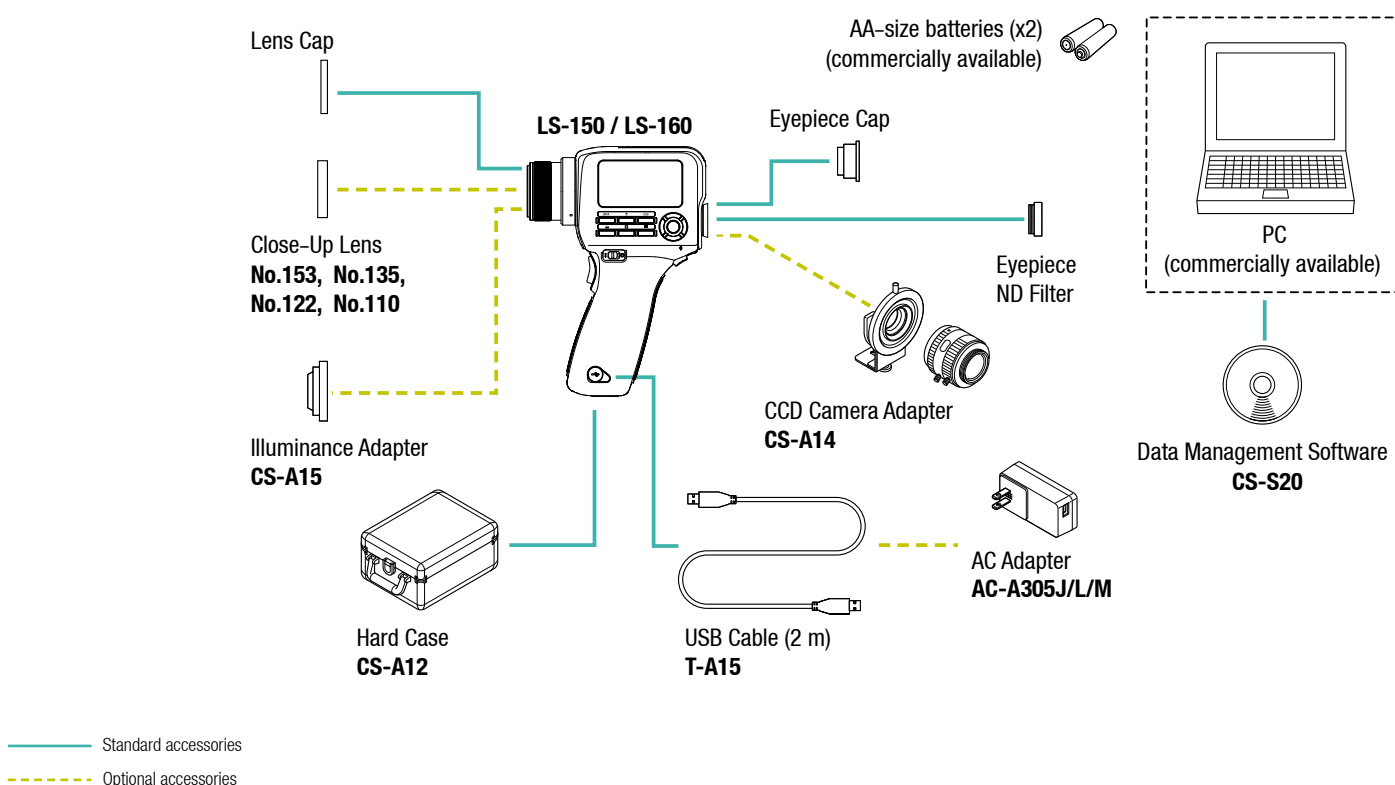

CL-200A - Main Specifications and Accessories

Model	Chroma Meter CL-200A
Illuminance meter class	Conforms to requirements for Class AA of JIS C 1609-1: 2006 "Illuminance meters Part 1: General measuring instruments"
Relative spectral response	Closely matches CIE Standard Observer curves $x(\lambda)$, $y(\lambda)$, and $z(\lambda)$ Within 6% (fi) of the CIE spectral luminous efficiency $V(\lambda)$
Cosine response (f_2)	E_V : Within 3%
Receptor	Silicon photocell
Measuring function	Tristimulus values: XYZ Chromaticity: E_{Vxy} ; $E_{Vu'v'}$; E_V , Dominant wavelength, Excitation purity Correlated colour temperature: $E_V T_{cp} \Delta uv$; T_{cp} (JIS method; available only with CL-S10w) Colour difference: $\Delta(XYZ)$, $\Delta(E_{Vxy})$, $\Delta(E_{Vu'v'})$, $\Delta E_{Vu'v'}$ (Target: 1)
Other function	User calibration function, Data hold function, Multi-point measurement (2 to 30 points)
Measuring range	0.1 to 99,990 lx, 0.01 to 9,999 fcd (Chromaticity: 5 lx, 0.5 fcd or above) in four automatically selected ranges (lx or fcd is switchable)
Accuracy*	E_V (Linearity): $\pm 2\% \pm 1$ digit of displayed value xy : ± 0.002
Repeatability*	E_V : $0.5\% + 1$ digit (2σ), xy : ± 0.0005
Temperature drift	E_V : $\pm 3\% \pm 1$ digit of displayed value, xy : ± 0.003
Humidity drift	E_V : $\pm 3\% \pm 1$ digit of displayed value, xy : ± 0.003
Response time	0.5 sec. (continuous measurement)
Computer interface	USB
Printer output	RS-232C
Display	4-significant-digit LCD with back-light illumination
Battery life	72 hours or longer (when alkaline batteries are used) in continuous measurement
Operating temperature / humidity range	-10 to 40°C, relative humidity 85% or less (at 35°C) with no condensation
Storage temperature / humidity range	-20 to 55°C, relative humidity 85% or less (at 35°C) with no condensation
Power source	2 AA-size batteries / AC adapter AC-308 (optional; for 1 to 10 receptors) or AC adapter AC-311 (optional; for 1 to 30 receptors)
Battery life	72 hours or longer (When alkaline batteries are used) in continuous measurement
Size	69 × 174 × 35mm (2-6 / 16×6-14 / 16×1-7/13in.)
Weight (without battery)	215g (7.6 oz.)

* 800 lx, Standard Illuminant A measured

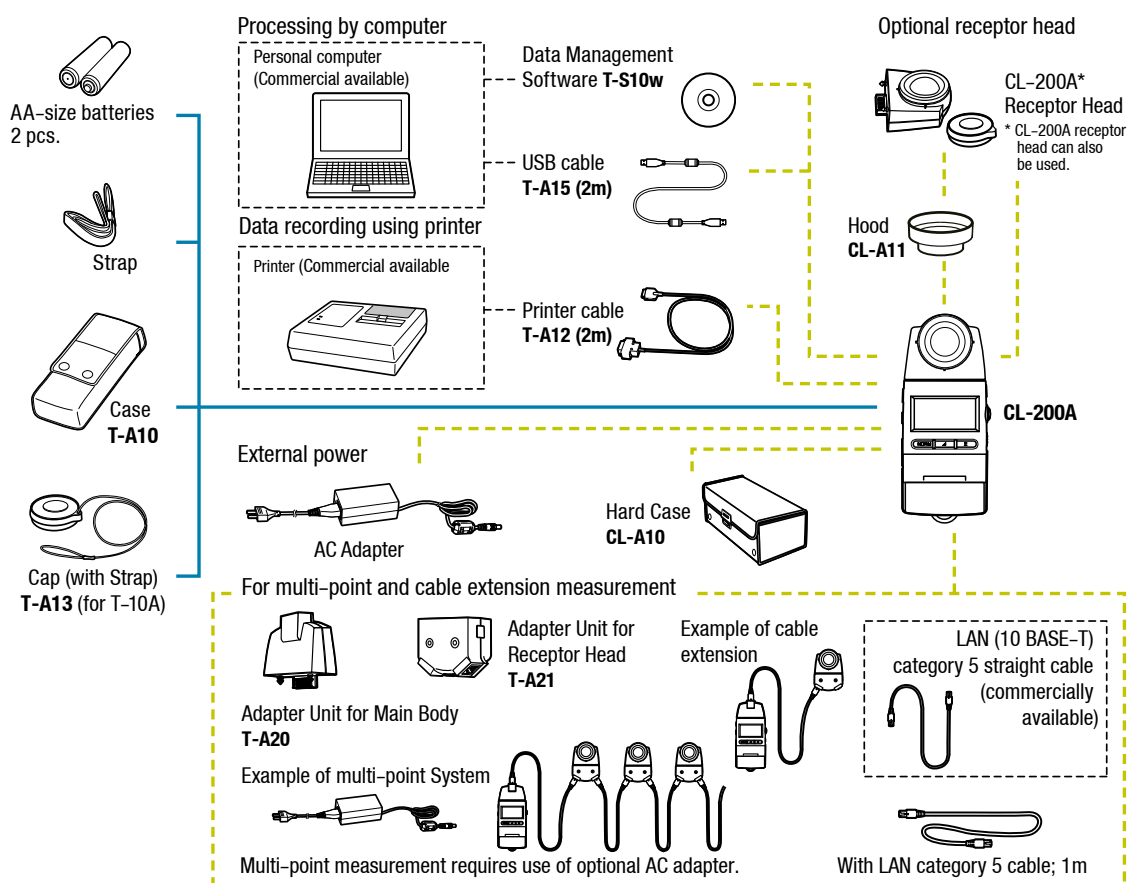

CL-70F - Main Specifications and Accessories

Model	CRI Illuminance Meter CL-70F
Illuminance meter class	Conforms to requirements for Class A of JIS C1609-1:2006 "Illuminance meters Part1:General measuring instruments; Conforms to DIN 5032 Part 7 Class C
Sensor	CMOS linear image sensor
Spectral wavelength range	380 nm ~ 780 nm
Output wavelength pitch	1 nm
Measuring range	Constant light: 1 to 200,000 lx; 1,563 to 100,000 K (Chromaticity display requires 5 lx or more) Flash light: 20 to 20,500 lx·s; 2,500 to 100,000 K
Accuracy (Standard Illuminant A) ^(1,2)	E_v : $\pm 5\% \pm 1$ digit of displayed value xy : ± 0.003 (at 800 lx)
Repeatability (Standard Illuminant A) ⁽¹⁾	E_v : 30 to 200,000 lx: 1%+1 digit; 1 to 30 lx: 5%+1 digit (*3) xy : 500 to 200,000 lx: 0.001 ⁽⁴⁾ xy : 100 to 500 lx: 0.002 ⁽⁴⁾ xy : 30 to 100 lx: 0.004 ⁽⁴⁾ xy : 5 to 30 lx: 0.008 ⁽⁴⁾
Visible-region relative spectral response characteristics (f_1)	Within 9%
Cosine correction characteristics (f_2)	Within 6%
Temperature drift (f_3)	E_v : $\pm 5\%$ xy : ± 0.006
Humidity drift (f_4)	E_v : $\pm 3\%$ xy : ± 0.006
Power	2 AA-size batteries (Alkaline batteries or manganese dry cells); USB bus power
Response time	Constant light (Maximum): 15 sec Constant light (Minimum): 0.5 sec Flash light: 1 ~ 1/500 sec (in 1-step intervals) (*5)
Colour indication modes	Correlated colour temperature T_{cp} , Difference from blackbody Δuv , XYZ, xy , $u'v'$, Dominant wavelength Δ_d , Excitation purity P_e , Spectral irradiance, E_v , CRI (Ra, Ri), Peak wavelength Δ_p , exposure value
Other functions	Data memory: 999 data; Preset function; Auto power off function
Display languages	English, Japanese, Chinese (Simplified)
Interface	USB 2.0 Mini B
Operation temperature / humidity range	-10 to 40°, relative humidity of 85% or less (at 35°) with no condensation
Storage temperature / humidity range	-10 to 45°, relative humidity of 85% or less (at 35°) with no condensation
Size	73 × 183 × 27 mm (Not including projecting buttons) D (max): 40 mm
Weight (without battery)	230 g

¹ Measurement mode: Constant light (range L), Exposure time / AUTO

² Linear for E_v

³ 10 times measurement (2σ) / Ave

⁴ 10 times measurement (2σ)

⁵ Shutter speed

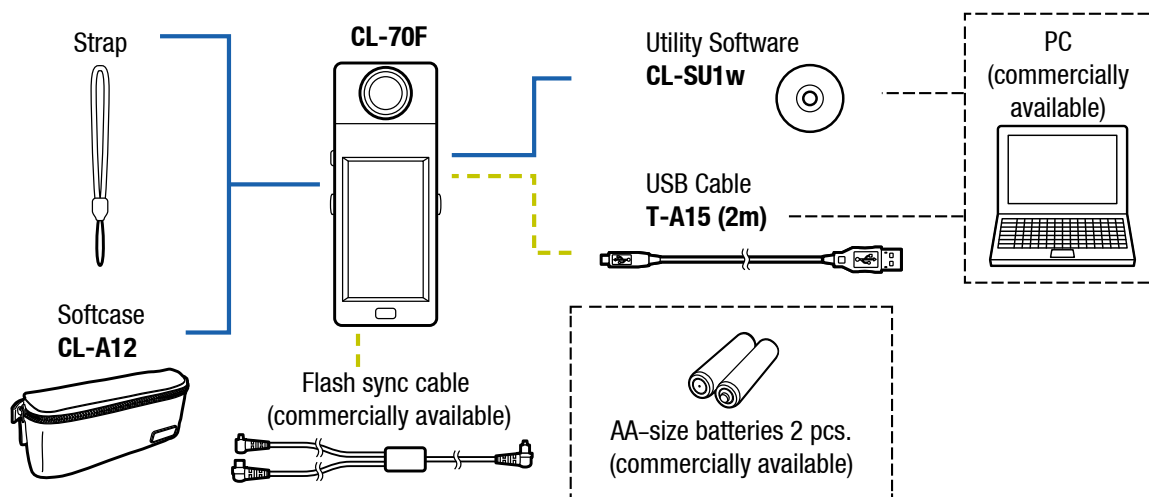

— Standard accessories

- - - Optional accessories

CL-500A - Main Specifications and Accessories

Model	Illuminance Spectrophotometer CL-500A
Illuminance meter class	Conforms to requirements for Class AA of JIS C 1609-1: 2006 "Illuminance meters Part 1: General measuring instruments" ^{1*} Conforms to DIN 5032 Part 7 Class B
Wavelength range	360 ~ 780 nm
Output wavelength pitch	1 nm
Spectral bandwidth	Approx. 10 nm (half bandwidth)
Wavelength precision	±0.3 nm (Median wavelengths of 435.8 nm, 546.1 nm, and 585.3 nm ² as specified in JIS Z 8724) ³
Measuring range	0.1 to 100,000 lx (chromaticity display requires 5 lx or more)
Accuracy^{4,5} (Standard Illuminant A)	E_v (Illuminance) : ±2%±1 digit of displayed value xy: ±0.0015 (10 to 100,000 lx) xy: ±0.002 (5 to 10 lx)
Repeatability (2σ)⁴ (Standard Illuminant A)	E_v : 0.5%+1 digit xy: 0.0005 (500 to 100,000 lx) xy: 0.001 (100 to 500 lx) xy: 0.002 (30 to 100 lx) xy: 0.004 (5 to 30 lx)
Visible-region relative spectral response characteristics (f₁)	Within 1.5% of spectral luminous efficiency V (λ)
Cosine response (f₂)	E_v : Within 3%
Temperature drift (f₇)	E_v : ±3% of displayed value; xy: ±0.003
Humidity drift (f₈)	E_v : ±3% of displayed value; xy: ±0.003
Measurement time	Super Fast mode: Approx. 0.2 sec. (when connected to computer); Fast mode: Approx. 0.5 sec.; Slow mode: Approx. 2.5 sec.; Automatic exposure time setting (high accuracy) mode: Approx. 0.5 to 27 sec.
Display modes	XYZ; X ₁₀ Y ₁₀ Z ₁₀ ; E _v xy; E _v u'v'; E _v ; Dominant wavelength, Excitation purity; Correlated colour temperature, Δuv ; General colour-rendering index (Ra); Special colour-rendering indexes (R _i (i=1~15)); Spectral graph; Peak wavelength; Δ (XYZ); Δ (X ₁₀ Y ₁₀ Z ₁₀); Δ (E _v xy); Δ (E _v u'v'); Rank display
Other functions	Data memory: 100 data; User calibration function (when connected to computer); Continuous measurement (when connected to computer); Auto power off function
Display languages	English, Japanese, Chinese (Simplified)
Interface	USB 2.0
Power	Rechargeable internal lithium-ion battery (Operating time per charge: Approx. 6 hours when new); AC adapter; USB power bus
Operation temperature / humidity range	-10 to 40°C, relative humidity of 85% or less (at 35°C) with no condensation
Storage temperature / humidity range	-10 to 45°C, relative humidity of 85% or less (at 35°C) with no condensation
Size	70 × 165 × 83 mm
Weight (without battery)	350 g

¹ For Section 7.6.3 Response Time, when measurement speed mode is set to FAST mode.

² For 585.3 nm, evaluation performed using substitute wavelength of 587.5 nm.

³ Based on Konica Minolta test standards (change in temperature of 2°C or less after zero calibration.)

⁴ Automatic exposure time setting (high accuracy) mode

⁵ Linear for E_v (Illuminance)

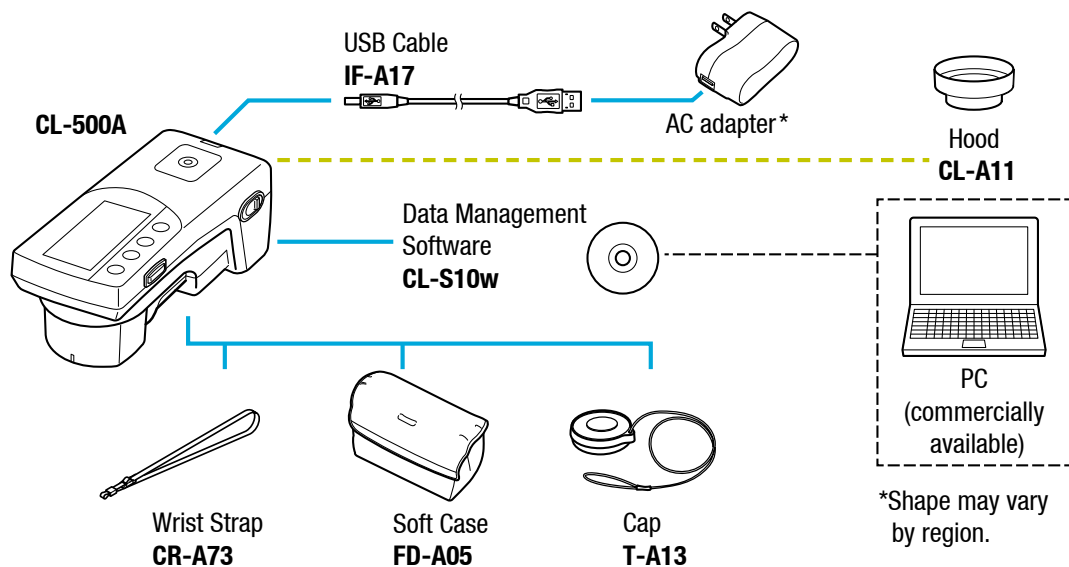

— Standard accessories

- - - Optional accessories

CS-150 / CS-160 - Main Specifications and Accessories

Model	Luminance Meter CS-150	Luminance Meter CS-160
Measuring angle	1°	1 / 3°
Optical system	SLR viewing system, f = 85 mm F2.8	
Angle of view	9° (with diopter adjustment)	
Relative spectral responsivity	Closely matches CIE 1931 colour matching function (x (λ), y (λ), z (λ))	
Minimum measuring area (diameter)	14.4 mm (1.3 mm when close-up lens is used)	4.5 mm (0.4 mm when close-up lens is used)
Minimum measuring distance (From the measuring distance reference plane)	1,012 mm (213 mm when close-up lens is used)	
Colour notations	(Absolute value) L _v , x, y (Y, x, y), L _v , u', v', L _v , T _{cp} , duv, XYZ, L _v , λ _d , P _e	
Measurement mode	(Luminance) Instantaneous value, maximum/minimum value, luminance difference (Δ)/luminance ratio (%) (Chromaticity) Instantaneous value, chromaticity difference (Δ)	
Measurement time	AUTO: 0.7 to 4.3 seconds / Manual: 0.7 to 7.1 seconds	
Luminance unit	cd /m ² or fL	
Luminance range	0.001 to 999,900 cd /m ²	0.01 to 9,999,000 cd /m ²
Accuracy ¹	(Luminance) ±2% ± 1 digit (Chromaticity) ±0.004 (5 cd /m ² or more)	(Luminance) ±2% ± 1 digit (Chromaticity) ±0.004 (50 cd /m ² or more)
Repeatability ¹	(Luminance) 0.2% + 1 digit (Chromaticity) 0.001 (10 cd/m ² or more) (Chromaticity) 0.002 (5 cd/m ² or more)	(Luminance) 0.2% + 1 digit (Chromaticity) 0.001 (100 cd/m ² or more) (Chromaticity) 0.002 (50 cd/m ² or more)
Calibration standard	Konica Minolta standard /user-specified standard switchable	
User calibration channels	10 channels	
Data memory	1,000 data	
External display (Number of significant digits)	(Luminance) 4 digits (Chromaticity) 4 digits	
Internal display (Number of significant digits)	(Luminance) 4 digits	
Interface	USB 2.0	
Power	AA-size bat teries (x2), USB bus power, or optional AC adapter	
Current consumption	When viewfinder display is lit: 70 mA average	
Operation temperature / humidity range	0 to 40°C, relative humidity of 85% or less (at 35°C)	
Storage temperature / humidity range	0 to 45°C, relative humidity of 85% or less (at 35°C)	
Size	71 × 214 × 154 mm	
Weight (without battery)	850 g	

¹ Standard Illuminant A; Standard measurement distance; Measurement time setting: Auto

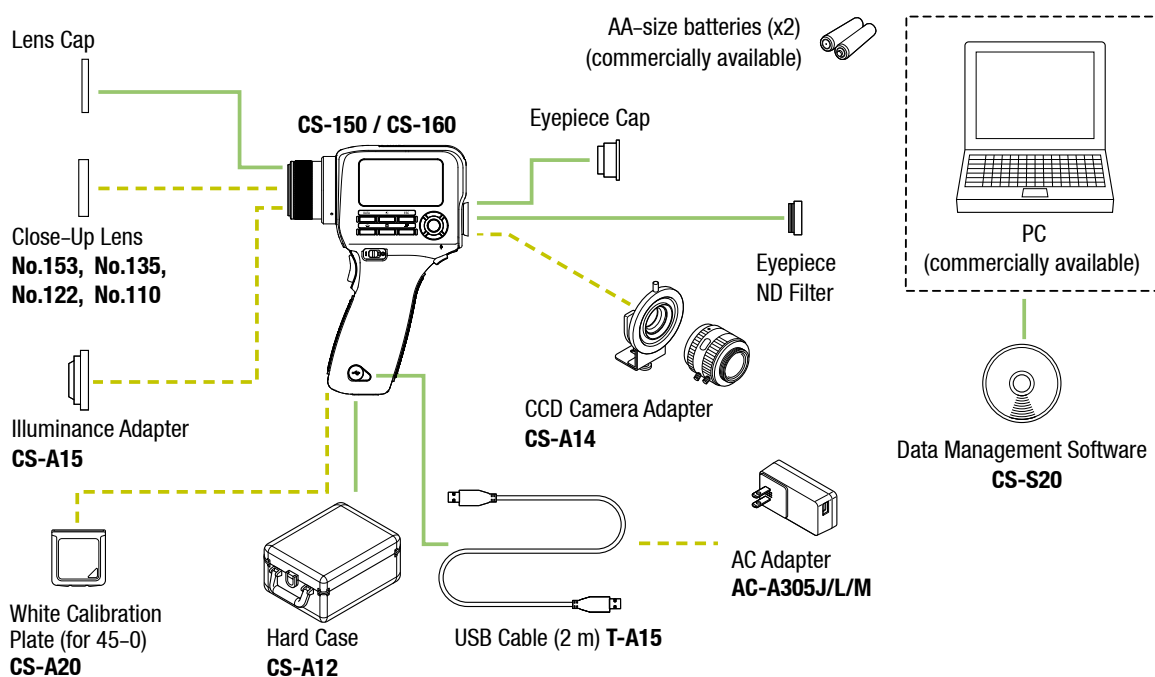

— Standard accessories

- - - Optional accessories

CS-200 - Main Specifications and Accessories

Model	Chroma Meter CS-200		
Measurement range	0.01 - 200,000cd/m ² (Measuring angle 1°) 0.01 - 5,000,000cd/m ² (Measuring angle 0.2°) 0.01 - 20,000,000cd/m ² (Measuring angle 0.1°)		
Accuracy (Measuring angle 1°) *1 (Standard Illuminant A; Temperature: 23°C±2°C, Relative humidity: 65% max.)	150 cd/m ² 0.01-0.5 cd/m ² 0.5-1 cd/m ² 1-10 cd/m ² 10-200,000 cd/m ²	L _v ±2 % ±1digit L _v ±0.02 cd/m ² ±1digit L _v ±0.02 cd/m ² ±1digit L _v ±2 % ±1digit L _v ±2 % ±1digit	xy ±0.002 ---- xy ±0.007 xy ±0.004 xy ±0.003
Repeatability (Measuring angle 1°) *2 (Standard Illuminant A)	0.01 - 1 cd/m ² 1 - 2 cd/m ² 2 - 4 cd/m ² 4 - 8 cd/m ² 8 - 200,000 cd/m ²	L _v 0.01 cd/m ² +1digit ---- L _v 0.5 % +1digit xy 0.002 L _v 0.5 % +1digit xy 0.001 L _v 0.5 % +1digit xy 0.0005 L _v 0.1 % +1digit xy 0.0004	(2σ/AUTO) (2σ/AUTO) (2σ/AUTO) (2σ/AUTO) (2σ/AUTO)
Measurement time	AUTO (Automatically set between approx. 1s and 60s) LTD.AUTO (Automatically set to approx. 1s or 3s) Super-FAST (approx. 0.5 sec/meas.) FAST (approx. 1 sec/meas.) SLOW (approx. 3 sec/meas.) Super-SLOW (approx. 12 sec/meas.)		
Measurement method	Spectral method, Grating + linear photo diode array		
Measuring angle	1°, 0.2°, 0.1° (switchable)		
Minimum measuring area	0.5 mm 0.1 mm (close up lens)		
Minimum measuring distance	296 mm (Distance from front edge of metal lens barrel)		
Observer	2° or 10° Standard Observer		
Colour space	L _v x _y , L _v u'v', L _v T _{Δuv} , XYZ, dominant wavelength		
Measurement synchronization setting range	Vertical synchronization frequency : 40.00 to 200.00 Hz		
Interface	USB 1.1		
Power	AC Adapter or 4 AA-Size Batteries		
Battery performance	Approx. 3 hours (continuous measurement / Fast mode / AA-size alkaline cells)		
Size	95 × 127 × 334 mm		
Weight (without battery)	1.8 kg		
Operation temperature / humidity range	0°C to 40°C, relative humidity 85% or less (at 35°C) with no condensation		
Storage temperature / humidity range	0°C to 45°C, relative humidity 85% or less (at 35°C) with no condensation		

*1 23°C ±2°C L_v = 0.01-10 cd/m², SLOW, average of 30 measurements

L_v = 10 cd/m² and higher, SLOW, average of 10 measurements

*2 At 0.2° measuring angle, the amount of received light is approx. 1/25 of that for 1°. Therefore, the repeatability becomes the same as that for 1° with 25 times lower luminance.
At 0.1° measuring angle, the amount of received light is approx. 1/100 of that for 1°. Therefore, the repeatability becomes the same as that for 1° with 100 times lower luminance.

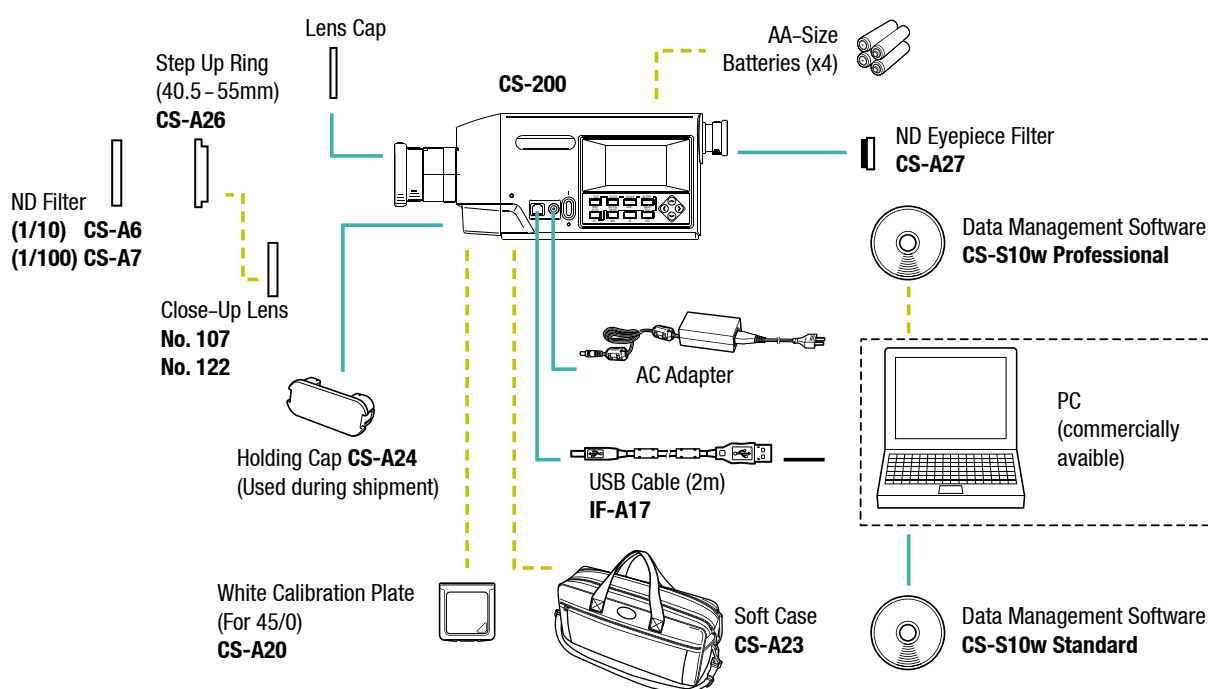

— Standard accessories

- - - Optional accessories

CS-2000 / CS-2000A - Main Specifications and Accessories

Model		Spectroradiometer CS-2000/2000A		
Wavelength range		380 to 780 nm		
Wavelength resolution		0.9 nm/pixel		
Display wavelength bandwidth		1.0 nm		
Wavelength precision		±0.3 nm (Median wavelength: 435.8 nm, 546.1 nm, 643.8 nm; Hg-Cd lamp)		
Spectral bandwidth		5 nm or less (half bandwidth)		
Measuring angle (selectable)		1°	0.2°	0.1°
Measurement luminance range (Standard light source A)	CS-2000	0.003 – 5,000 cd/m ²	0.075 – 125,000 cd/m ²	0.3 – 500,000 cd/m ²
	CS-2000A	0.0005 – 5,000 cd/m ²	0.0125 – 125,000 cd/m ²	0.05 – 500,000 cd/m ²
Minimum measuring area		ø 5 mm (ø 1 mm when using close-up lens)	ø 1 mm (ø 0.2 mm when using close-up lens)	ø 0.5 mm (ø 0.1 mm when using close-up lens)
Minimum measuring distance		350 mm (55 mm when using close-up lens)		
Minimum spectral radiance display		1.0x10 ⁻⁹ W/sr, m ² , nm		
Accuracy: Luminance (Standard light source A) ¹		±2%		
CS-2000	Accuracy: Chromaticity (Standard light source A) ¹	x,y : ±0.003 (0.003 – 0.005 cd/m ²) x,y : ±0.002 (0.005 – 0.05 cd/m ²) x : ±0.0015 (0.05 cd/m ² or more) y : ±0.001 (0.05 cd/m ² or more)	x,y : ±0.003 (0.075 – 0.125 cd/m ²) x,y : ±0.002 (0.125 – 1.25 cd/m ²) x : ±0.0015 (1.25 cd/m ² or more) y : ±0.001 (1.25 cd/m ² or more)	x,y : ±0.003 (0.3 – 0.5 cd/m ²) x,y : ±0.002 (0.5 – 5 cd/m ²) x : ±0.0015 (5 cd/m ² or more) y : ±0.001 (5 cd/m ² or more)
	Repeatability: Luminance (2σ) (Standard light source A) ²	0.4% (0.003 – 0.05 cd/m ²) 0.3% (0.05 – 0.1 cd/m ²) 0.15% (0.1 – 5,000 cd/m ²)	0.4% (0.075 – 1.25 cd/m ²) 0.3% (1.25 – 2.5 cd/m ²) 0.15% (2.5 – 125,000 cd/m ²)	0.4% (0.3 – 5 cd/m ²) 0.3% (5 – 10 cd/m ²) 0.15% (10 – 500,000 cd/m ²)
	Repeatability: Chromaticity (2σ) (Standard light source A) ²	x,y : 0.002 (0.003 – 0.005 cd/m ²) x,y : 0.001 (0.005 – 0.1 cd/m ²) x,y : 0.0006 (0.1 – 0.2 cd/m ²) x,y : 0.0004 (0.2 – 5,000 cd/m ²)	x,y : 0.002 (0.075 – 0.125 cd/m ²) x,y : 0.001 (0.125 – 2.5 cd/m ²) x,y : 0.0006 (2.5 – 5 cd/m ²) x,y : 0.0004 (5 – 125,000 cd/m ²)	x,y : 0.002 (0.3 – 0.5 cd/m ²) x,y : 0.001 (0.5 – 10 cd/m ²) x,y : 0.0006 (10 – 20 cd/m ²) x,y : 0.0004 (20 – 500,000 cd/m ²)
CS-2000A	Accuracy: Chromaticity (Standard light source A) ¹	x,y : ±0.002 (0.001 – 0.05 cd/m ²) x : ±0.0015 (0.05 cd/m ² or more) y : ±0.001 (0.05 cd/m ² or more)	x,y : ±0.002 (0.025 – 1.25 cd/m ²) x : ±0.0015 (1.25 cd/m ² or more) y : ±0.001 (1.25 cd/m ² or more)	x,y : ±0.002 (0.1 – 5 cd/m ²) x : ±0.0015 (5 cd/m ² or more) y : ±0.001 (5 cd/m ² or more)
	Repeatability: Luminance (2σ) (Standard light source A) ²	1.5% (0.0005 – 0.001 cd/m ²) 0.7% (0.001 – 0.003 cd/m ²) 0.25% (0.003 – 0.05 cd/m ²) 0.15% (0.05 – 5,000 cd/m ²)	1.5% (0.0125 – 0.025 cd/m ²) 0.7% (0.025 – 0.075 cd/m ²) 0.25% (0.075 – 1.25 cd/m ²) 0.15% (1.25 to 125,000 cd/m ²)	1.5% (0.05 to 0.1 cd/m ²) 0.7% (0.1 to 0.3 cd/m ²) 0.25% (0.3 to 5 cd/m ²) 0.15% (5 to 500,000 cd/m ²)
	Repeatability: Chromaticity (2σ) (Standard light source A) ²	x: 0.003 y: 0.0035 (0.001 to 0.003 cd/m ²) x: 0.001 y: 0.0015 (0.003 to 0.1 cd/m ²) x,y: 0.0006 (0.1 to 0.2 cd/m ²) x,y: 0.0004 (0.2 to 5,000 cd/m ²)	x: 0.003 y: 0.0035 (0.025 to 0.075 cd/m ²) x: 0.001 y: 0.0015 (0.075 to 2.5 cd/m ²) x,y: 0.0006 (2.5 to 5 cd/m ²) x,y: 0.0004 (5 – 125,000 cd/m ²)	x: 0.003 y: 0.0035 (0.1 – 0.3 cd/m ²) x: 0.001 y: 0.0015 (0.3 – 10 cd/m ²) x,y : 0.0006 (10 – 20 cd/m ²) x,y : 0.0004 (20 – 500,000 cd/m ²)
Polarization error		1°: 2% or less (400 to 780 nm); 0.1° and 0.2°: 3% or less (400 – 780 nm)		
Integration time		Fast: 0.005 to 16 sec.; Normal: 0.005 – 120 sec.		
Measurement time		CS-2000 : Approx. 2 sec. minimum (Manual mode) to 243 sec. maximum (Normal mode)		CS-2000A : Approx. 2 sec. minimum (Manual mode) to 247 sec. maximum (Normal mode)
Colour space mode		L _x y _y , L _v u ^v , L _v TΔuv, XYZ, spectral graph, dominant wavelength, excitation purity, scotopic luminosity (with CS-S10w Professional)		
Interface		USB 1.1		
Operating temperature / humidity range		CS-2000 : 5 to 35°C, relative humidity 80% or less with no condensation		CS-2000A : 5 to 30°C, relative humidity 80% or less with no condensation
Storage temperature / humidity range		0 to 35°C, relative humidity 80% or less with no condensation		
Power		AC adapter (100 – 240 V $\overline{\sim}$, 50/60 Hz)		
Size		158 × 200 × 300 mm (Main unit), ø 70 × 95 mm (Lens)		
Weight		6.2 kg		

¹ Average of 10 measurements in Normal mode at a temperature of 23±2°C and a relative humidity of 65% or less.

² 10 measurements in Normal mode at a temperature of 23±2°C and a relative humidity of 65% or less.

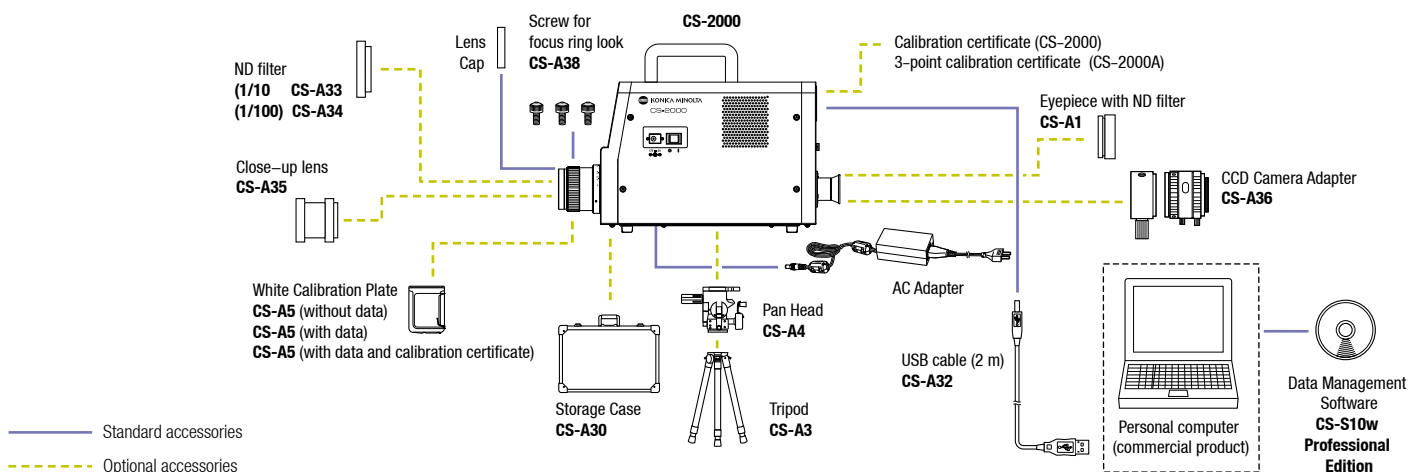

CA-310 - Main Specifications and Accessories

Model	CA-310 (LED Universal Measuring Ø27 Probe)	CA-310 (LED Universal Measuring Ø10 Probe)	CA-310 (LED Flicker Measuring Ø27 Probe)	CA-310 (LED Flicker Measuring Ø10 Probe)	
Receptor	Detector: Silicon photo cell				
Measurement area	ø27 mm	ø10 mm	ø27 mm	ø10 mm	
Acceptance angle	±2.5°	±5°	±2.5°	±5°	
Measurement distance	30±10 mm	30±5 mm	30±10 mm	30±5 mm	
Display range	Luminance	0.0001 - 1000 cd/m ²	0.0001 - 3000 cd/m ²	0.0001 - 1000 cd/m ²	
	Chromaticity	Displayed in 4 or 3-digit value (Can be chosen)			
Luminance	Measurement range	0.0050 - 1000 cd/m ²	0.0150 - 3000 cd/m ²	0.0050 - 1000 cd/m ²	
	Accuracy (for white) *1	0.0050 - 0.0999 cd/m ² ±4%±0.0015 cd/m ² 0.1000 - 9.999 cd/m ² ±3%±0.0010 cd/m ² 10.00 - 1000 cd/m ² ±2%±0.0010 cd/m ²	0.0150 - 0.2999 cd/m ² ±4%±0.0045 cd/m ² 0.3000 - 29.99 cd/m ² ±3%±0.0030 cd/m ² 30.00 - 3000 cd/m ² ±2%±0.0030 cd/m ²	0.0050 - 0.0999 cd/m ² ±4%±0.0015 cd/m ² 0.1000 - 9.999 cd/m ² ±3%±0.0010 cd/m ² 10.00 - 1000 cd/m ² ±2%±0.0010 cd/m ²	0.0150 - 0.2999 cd/m ² ±4%±0.0045 cd/m ² 0.3000 - 29.99 cd/m ² ±3%±0.0030 cd/m ² 30.00 - 3000 cd/m ² ±2%±0.0030 cd/m ²
	Repeatability (2σ) *1	0.0050 - 0.0999 cd/m ² 1% + 0.0010 cd/m ² 0.1000 - 0.9999 cd/m ² 0.2% + 0.0010 cd/m ² 1.000 - 1000 cd/m ² 0.1%+0.0010 cd/m ²	0.0150 - 0.2999 cd/m ² 1% + 0.0030 cd/m ² 0.3000 - 2.999 cd/m ² 0.2% + 0.0030 cd/m ² 3.000 - 3000 cd/m ² 0.1% + 0.0030 cd/m ²	0.0050 - 0.0999 cd/m ² 1% + 0.0010 cd/m ² 0.1000 - 0.9999 cd/m ² 0.2% + 0.0010 cd/m ² 1.000 - 1000 cd/m ² 0.1%+0.0010 cd/m ²	0.0150 - 0.2999 cd/m ² 1% + 0.0030 cd/m ² 0.3000 - 2.999 cd/m ² 0.2% + 0.0030 cd/m ² 3.000 - 3000 cd/m ² 0.1% + 0.0030 cd/m ²
Chromaticity	Measurement range	0.0500 - 1000 cd/m ²	0.1500 - 3000 cd/m ²	0.0500 - 1000 cd/m ²	
	Accuracy *1 (temperature: 23° ±2°, relative humidity: (40±10%))	0.0500 - 4.999 cd/m ² ±0.005 for white 5.000 - 19.99 cd/m ² ±0.004 for white 20.00 - 1000 cd/m ² ±0.003 for white 120 cd/m ² ±0.002 for white (±0.004 for monochrome)*2	0.1500 - 14.99 cd/m ² ±0.005 for white 15.00 - 59.99 cd/m ² ±0.004 for white 60.00 to 3000 cd/m ² ±0.003 for white 120 cd/m ² ±0.002 for white (±0.004 for monochrome)*2	0.0500 - 4.999 cd/m ² ±0.005 for white 5.000 - 19.99 cd/m ² ±0.004 for white 20.00 - 1000 cd/m ² ±0.003 for white 120 cd/m ² ±0.002 for white (±0.004 for monochrome)*2	0.1500 - 14.99 cd/m ² ±0.005 for white 15.00 - 59.99 cd/m ² ±0.004 for white 60.00 - 3000 cd/m ² ±0.003 for white 120 cd/m ² ±0.002 for white (±0.004 for monochrome)*2
	Repeatability(2σ) *2	0.0500 to 0.0999 cd/m ² 0.010 0.1000 to 0.1999 cd/m ² 0.004 0.2000 to 0.4999 cd/m ² 0.002 0.5000 to 1000 cd/m ² 0.001	0.1500 to 0.2999 cd/m ² 0.010 0.3000 to 0.5999 cd/m ² 0.004 0.6000 to 1.499 cd/m ² 0.002 1.500 to 3000 cd/m ² 0.001	0.0500 to 0.0999 cd/m ² 0.010 0.1000 to 0.1999 cd/m ² 0.004 0.2000 to 0.4999 cd/m ² 0.002 0.5000 to 1000 cd/m ² 0.001	0.1500 to 0.2999 cd/m ² 0.010 0.3000 to 0.5999 cd/m ² 0.004 0.6000 to 1.499 cd/m ² 0.002 1.500 to 3000 cd/m ² 0.001
Flicker Contrast method	Measurement range	-		5 cd/m ² or higher	
	Display range	-		0.0 ~ 999.9 %	
	Accuracy	-		±1 % (Flicker frequency: 30 Hz AC/DC 10% sine wave) ±2 % (Flicker frequency: 60 Hz AC/DC 10% sine wave)	
Flicker JEITA method *3	Measurement range	-		5 cd/m ² or higher	
	Accuracy	-		±0.5 dB (Flicker frequency: 30 Hz AC/DC 10% sine wave)	
	Repeatability (2σ)	-		0.3 dB (Flicker frequency: 30 Hz AC/DC 10% sine wave)	
Measurement speed *1	xyLV	0.0050 to 0.0999 cd/m ² 4(3.5) times/sec. 0.1000 to 1.999 cd/m ² 5(4.5) times/sec. 2.000 to 1000 cd/m ² 20(17) times/sec.	0.0150 to 0.2999 cd/m ² 4(3.5) times/sec. 0.3000 to 0.5999 cd/m ² 5(4.5) times/sec. 6.000 to 3000 cd/m ² 20(17) times/sec.	0.0050 to 0.0999 cd/m ² 4(3.5) times/sec. 0.1000 to 1.999 cd/m ² 5(4.5) times/sec. 2.000 to 1000 cd/m ² 20(17) times/sec.	0.0150 to 0.2999 cd/m ² 4(3.5) times/sec. 0.3000 to 0.5999 cd/m ² 5(4.5) times/sec. 6.000 to 3000 cd/m ² 20(17) times/sec.
	Flicker Contrast	-		16(16) times/sec.	
	Flicker JEITA *3	-		0.5 (0.3) times/sec. *5	
Display	Digital	xyLV, TΔuvLV, RGB analyze, XYZ, u'v'LV		xyLV, TΔuvLV, RGB analyze, XYZ, u'v'LV, Flicker (Contrast method) *3	
	Analog	ΔxΔyΔLV, R/G B/G ΔG, ΔR B/R G/R		ΔxΔyΔLV, R/G B/G ΔG, ΔR B/R G/R, Flicker (Contrast method) *3	
	LCD	16 characters by 2 lines (with backlight)			
SYNC mode	NTSC, PAL, EXT, UNIV, INT				
Object under measurement	Vertical synchronization frequency: 40 to 200 Hz		Vertical synchronization frequency: 40 to 200 Hz (Luminance or chromaticity measurement), 40 to 130 Hz (Flicker measurement)		
Memory channel	100 channels				
Analyzer function	Standard function				
Interface	USB; RS-232C (38,400 bps or below)				
Multi-point Measurement	Max. 5 points (Use 4-Probe Expansion Board CA-B15)				
Operating temperature / humidity range	Temperature: 10 to 28°C; relative humidity 70% or less with no condensation Luminance change: ±2% of reading for white Chromaticity change ±0.002 for white, ±0.006 for monochrome from reading of Konica Minolta's standard LCD *1, 120 cd/m ² , with 23°C 40%				
Storage temperature / humidity range	0 to 28°C: relative humidity 70% or less with no condensation 28 to 40°C: relative humidity 40% or less with no condensation				
Input voltage range	100-240V~, 50-60 Hz, 50 VA				
Size/weight	Main body	340 × 127 × 216 mm / 3.58 kg			
	Probe	ø49 × 208 mm / 530 g	ø49 × 236 mm / 550 g	ø49 × 208 mm / 530 g	

*1 The chromaticity and luminance are measured under Konica Minolta's condition (standard LCD (6500K, 9300K) is used).

*2 The luminance for monochrome is measured when the reading of luminance for white is 120 cd/m².

*3 Measurement of flicker (JEITA method) is supported by SDK software.

*4 Measuring probe connected to probe connector P1 only, used USB (used RS-232C Baud rate: 38400 bps)

*5 Measured by Konica Minolta's PC (P3-600 MHz)

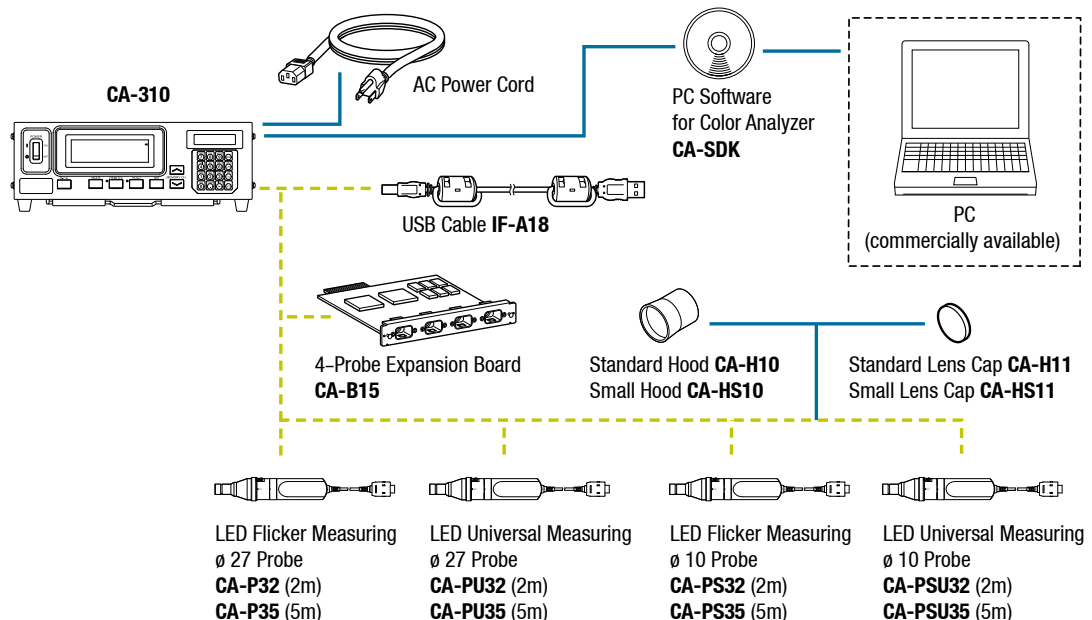

CA-2500 - Main Specifications and Accessories

Model	CA-2500S	CA-2500W	CA-2500T			
Light receptor	CCD image sensor (monochrome); 2/3-inch; Effective number of pixels: 1,000 x 1,000 pixels; Equipped with XYZ filter (closely matches CIE 1931 colour-matching function) and ND filter					
Lens	Interchangeable Standard, wide, and telephoto lenses; low-magnification and high-magnification macro rings (for use with telephoto lens)					
Measurement points (Resolution)	980 x 980 (490 x 490 or 196 x 196 selectable by using Data Management Software CA-S25w)					
Colour indication modes	XYZ, L _v xy, L _v u'v', TΔuv, Dominant wavelength, Excitation purity, L _v contrast					
Display modes	Pseudocolour, Chromaticity diagram, Spot, Cross section, Colour difference					
Measurement sizes (length per side of square) ^{*1}	Standard lens	Wide lens	Telephoto lens	With low-magnification macro ring	With high-magnification macro ring	
	Approx. 98 mm or more (depending on the distance)	Approx. 145 mm or more (depending on the distance)	Approx. 115 mm or more (depending on the distance)	Approx. 57mm (Fixed)	Approx. 27mm (Fixed)	
Measurable size for typical measurement distances (size/distance)	98 mm / 250 mm Approx.	145 mm / 200 mm Approx.	115 mm / 900 mm Approx.	57 mm / 500 mm Approx. (Fixed)	27 mm / 300 mm Approx. (Fixed)	
	210 mm / 500 mm Approx.	410 mm / 500 mm Approx.	275 mm / 2,000 mm Approx.			
	440 mm / 1,000 mm Approx.	850 mm / 1,000 mm Approx.	420 mm / 3,000 mm Approx.			
	890 mm / 2,000 mm Approx.	1,770 mm / 2,000 mm Approx.				
Measurement luminance range (including ND filter use)	0.05 - 100,000 cd/m ²	0.05 - 100,000 cd/m ²	0.25 - 100,000 cd/m ²	0.25 - 100,000 cd/m ²	0.5 - 100,000 cd/m ²	
Measurement time	Single : Approx. 5 sec. or more; 4-time integration: Approx. 6 sec. or more; 16-time integration: Approx. 10 sec. or more; 64-time integration : Approx. 25 sec. or more; 256-time integration : Approx. 80 sec. or more					
Accuracy	Luminance	±3 %	±3 %	±3 %	±3 %	±3 %
	Chromaticity	±0.005	±0.005	±0.005	±0.005	±0.005
Repeatability	Luminance	0.5 %	0.5 %	0.5 %	0.5 %	0.5 %
	Chromaticity	0.001	0.001	0.001	0.001	0.001
Inter-point error	Luminance	±2 %	±2 %	±2 %	±2 %	±2 %
	Chromaticity	±0.002	±0.002	±0.002	±0.002	±0.002
	Luminance	±3 %	±3 %	±3 %	±3 %	±3 %
	Chromaticity	±0.003	±0.003	±0.003	±0.003	±0.003
Other functions	Measurement sync (Synchronization frequency selectable), User calibration Integration function					
Interface	USB 2.0 or higher					
Operating temperature and humidity range	10-30°C, Relative humidity 70% or less/No condensation					
Storage temperature and humidity range	0-30°C, Relative humidity 70% or less/No condensation, 30-35°C, Relative humidity 55% or less/No condensation					
Size	Body only	160 × 164 × 192 mm (Height including handle: 211 mm)				
	When lens and lens hood are attached	224 (D) mm	219 (D) mm	224 (D) mm	230 (D) mm	237 (D) mm
Weight	3.5 kg approx. (when standard lens and lens hood are attached)					
Power source	AC adapter 100-240 V ~, 0.75 A, 50-60 Hz					

*1 Error in angle of view: 7%

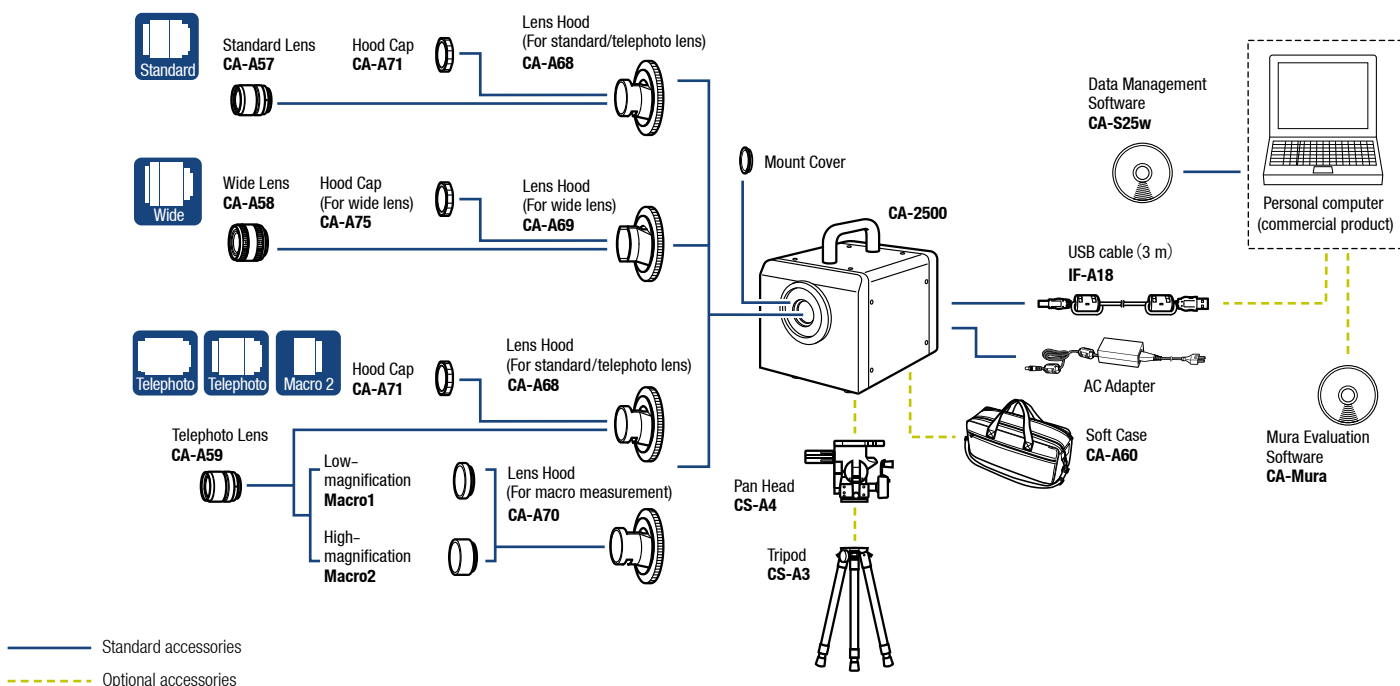

KONICA MINOLTA, INC
Konica Minolta Sensing Americas, Inc.

Osaka, Japan
New Jersey, U.S.A.

Konica Minolta Sensing Europe B.V.

European Headquarter
German Office
French Office
UK Office
Italian Office
Swiss Office
Polish Office
Belgium Office
Nordic Office
SE Sales Division
Beijing Office
Guangzhou Office
Chongqing Office
Qingdao Office
Wuhan Office

Nieuwegein, Netherlands
München, Germany
Roissy CDG, France
Warrington, United Kingdom
Cinisello Balsamo, Italy
Dietikon, Switzerland
Wroclaw, Poland
Zaventem, Belgium
Västra Frölunda, Sweden
Shanghai, China
Beijing, China
Guangzhou, China
Chongqing, China
Shandong, China
Hubei, China
Singapore
Goyang-si, Korea
Bangkok, Thailand

Phone: +1-888-473-2656 (in USA)
Phone: +1-201-236-4300 (outside USA)

Phone: +31 (0) 30 248-1193
Phone: +49 (0) 89 4357 156 0
Phone: +33 (0) 1 80-11 10 70
Phone: +44 (0) 1925 467300
Phone: +39 028 49488.00
Phone: +41 (0) 43 322-9800
Phone: +48 (0) 71 734 52-11
Phone: +32 (0) 2 7170-933
Phone: +46 (0) 31 7099464
Phone: +86-(0) 21-5489 0202
Phone: +86-(0) 10-8522 1551
Phone: +86-(0) 20-3826 4220
Phone: +86-(0) 23-6773 4988
Phone: +86-(0) 532-8079 1871
Phone: +86-(0) 27-8544 9942
Phone: +65 6563-5533
Phone: +82 (0) 2-523-9726
Phone: +66-2361-3730

marketing.SUS@konicaminolta.com

info.sensing@seu.konicaminolta.eu
info.germany@seu.konicaminolta.eu
info.france@seu.konicaminolta.eu
info.uk@seu.konicaminolta.eu
info.italy@seu.konicaminolta.eu
info.switzerland@seu.konicaminolta.eu
info.poland@seu.konicaminolta.eu
info.benelux@seu.konicaminolta.eu
info.nordic@seu.konicaminolta.eu
hcn_sensing@hcn.konicaminolta.cn
hcn_sensing@hcn.konicaminolta.cn
hcn_sensing@hcn.konicaminolta.cn
hcn_sensing@hcn.konicaminolta.cn
hcn_sensing@hcn.konicaminolta.cn
cn_sensing@hcn.konicaminolta.cn
ssg@konicaminolta.sg
sensing-gc@konicaminolta.jp
sensing-gc@konicaminolta.jp

Konica Minolta (CHINA) Investment Ltd.

SE Sales Division
Beijing Office
Guangzhou Office
Chongqing Office
Qingdao Office
Wuhan Office

Konica Minolta Sensing Singapore Pte Ltd.
Konica Minolta Sensing, Inc.

Optics Company, Korea
Optics Company, Sensing Business
Thailand Representative Office

Addresses and telephone numbers are subject to change without notice. For the latest contact information, please refer to the KONICA MINOLTA Worldwide Offices web page:

<http://konicaminolta.com/instruments/network>



Certificate No: WA 0937 154
Registration Date:
March 3, 1995



Certificate No: JQA-E-80027
Registration Date:
March 12, 1997

